

SP 900



Table of contents

General Information	3	Standby mode	30
Symbols	3	DIP 5 ON: Standby deactivated	30
Safety instructions	3	Overload protection	30
Intended use	4	Operation after a power failure	30
Permitted gate wing dimensions	4	Maintenance and care	31
Technical data	4	Safety instructions	31
Dimensions	4	Regular testing	31
General Information	5	Description of the flash sequences of the LEDs	32
Installation preparations	6	DIP switch settings	33
Safety instructions	6	Emergency release	34
Tools required	6	Disassembly	34
Personal safety equipment	6	Disposal	34
Scope of supply	7	Disassembly and disposal	34
Package 1	7	Wiring diagram	35
Package 2	7		
Tips for installation	8		
Installation	9		
Foundation	9		
Installation of column	9		
Installing the drive	12		
Installing the racks	13		
Adjusting tooth play	14		
Safety instructions	16		
Installation location	16		
Connection	16		
Mains connection	17		
Connecting safety devices	17		
Connecting button	19		
Optional connections	20		
Radio-based safety contact strip	20		
Connection / Commissioning	20		
Battery pack	21		
Safety instructions	23		
Connecting the power supply	23		
Commissioning / Operation	23		
Installing limit switches	24		
Rest control unit	25		
Programming	25		
Safety instructions	26		
Radio receiver	26		
Explanation of radio channels	26		
Pulse sequence of gate movements	26		
Deleting the radio receiver memory	27		
Deleting a channel from the radio receiver	27		
Programming the hand-held remote control	27		
Deleting the hand-held transmitter from the radio receiver	27		
Finishing commissioning	27		
Safety instructions	28		
Open gate	28		
Close gate	28		
Partial opening	28		
Automatic closing function	29		
Pre-warning time	29		
Dead man operation	29		
Obstacle detection	30		

General Information

Symbols



ATTENTION SYMBOL:

Important safety instructions!

Attention - to ensure personal safety, it is important to observe all instructions. Save these instructions!



NOTE SYMBOL:

Information, useful advice!

1 (1) Refers to a respective picture in the introduction or main text.

Safety instructions

General

- These installation and operating instructions must be read, understood and complied with by persons who install, use or perform maintenance on the drive.
- Keep this installation and operating manual accessible at all times.
- Installation, connection and initial commissioning of the drive may only be carried out by technically knowledgeable persons.
- Install the drive on correctly aligned gates only. An improperly aligned gate can cause serious injuries or damage the drive.
- The manufacturer assumes no liability for injuries, damage or breakdowns that occur due to non-compliance with the installation and operating instructions.
- Always ensure compliance with accident prevention regulations and current standards in each respective country.
- Observe and comply with the "ASRA1.7 Technical Regulations for Workplaces" of the German Committee for Workplaces (ASTA), which is mandatory for the operator in Germany.
- Before any work on the drive disconnect it from the power supply and lock it to prevent reconnection. This also includes disconnection of a battery, if present.
- All electrical wiring must be firmly secured to prevent displacement
- Only use OEM (Original Equipment Manufacturer) spare parts, accessories and mounting material.

Storage

- The drive must be stored in an enclosed, dry area at a room temperature of -20 - +50 °C.
- The drive should be stored horizontally.

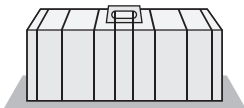
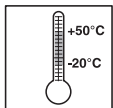

Operation

- The drive must be operated only if a non-hazardous force tolerance is set or safety is guaranteed by other safety equipment. The force tolerance must be set low enough to eliminate any danger of injury by the closing force (see "Maintenance and care").
- Never put your hand near the gate when it is moving or near moving parts.
- Drive through the gate only when it has opened completely.
- There is a risk of persons being crushed or cut by the mechanism or sharp edges of the gate.
- For automatic closing the main and auxiliary closing edges must be secured in accordance with the applicable directives and standards.
- Open and close the gate only if there are no children, persons, animals, or objects within its range of motion.
- Regularly check the safety and protection functions and repair faults when they are detected. See Care and maintenance.

Radio remote control

- The remote control must only be used for devices and systems in which radio interference will not endanger people, animals or objects or the risk is reduced by other safety devices.
- The user must be made aware that systems that pose an accident risk should only be remote controlled, if at all, if the user can actually see the gate.
- The radio remote control may only be used if the gate's movement can be watched and no persons or objects are within the range of movement.
- Store the hand-held transmitter so that unintended operation, e.g., by children or animals, is impossible.
- The operator of the radio system is not protected from faults due to other telecommunications equipment or devices (e.g. radio-controlled systems that are licensed to operate in the same frequency range). If substantial interference occurs, please contact your appropriate telecommunications office which has radio interference measuring equipment (radiolocation).
- Do not operate the hand-held transmitter in areas with sensitive radio communications or systems (e.g. airports, hospitals).

Type plate

- The type plate is attached to the inside of the base frame/housing. The type plate shows the exact type designation and the date of manufacture (month/year) of the drive.

General Information

Intended use

- The drive is exclusively intended to open and close sliding gates (see EN 12433-1). Any other use does not constitute intended use. The manufacturer accepts no liability resulting from use other than intended use. The user bears the sole responsibility for any risk involved. The warranty expires as a result.
- Gates automated with a drive must comply with all valid standards and directives: e.g. EN 12604, EN 12605.
- Maintain the safety clearances between the gate and surroundings as specified in EN 12604.
- The drive must be in good technical condition, and it must be used for its intended purpose with awareness of the hazards as described by the installation and operating manual.
- The gate must not have any rise or fall during opening or closing.
- Position the running rail to allow water to drain to prevent ice accumulation in winter.
- The gate must move freely in the guide and on the running rail to allow the drive to react sensitively and the gate to be switched off in emergency.
- The gate must have end stops in open and closed position, otherwise it may be pushed out of the guide in the event of an emergency release.
- Malfunctions which could affect safety must be corrected immediately.
- The gate must be stable and rigid, meaning that it may not bend or twist when being opened or closed.
- The drive cannot compensate for defects in the gate or incorrect assembly or installation.
- Do not install drive in explosive areas.
- Do not operate drive in rooms with aggressive atmosphere.

**For the Declaration of Conformity for
the radio see:**

www.sommer.eu/mrl

Permitted gate wing dimensions

Min. path:	1,400 mm
Max. path:	8,000 mm
Weight:	400 kg
Gate inclination:	0%

Technical data

Rated voltage	220 - 230 V AC
Rated frequency	50/60 Hz
Operating temperature range	-20 to + 60 °C
Degree of protection	Operator: IP 44 control unit: IP 64
Max. tension and compress. force	900 N
Rated tension force	300 N
Rated current consumption	0.2 A
Rated wattage	46 W
Max. speed	285 mm/s
Power consumption, stand-by	0.5 W
Operating time	40% S3
Max. movement cycles per day	40

Workplace-related emission value < 75 dBA - drive only.

Dimensions

All dimensions are in millimetres. The drive is locked.

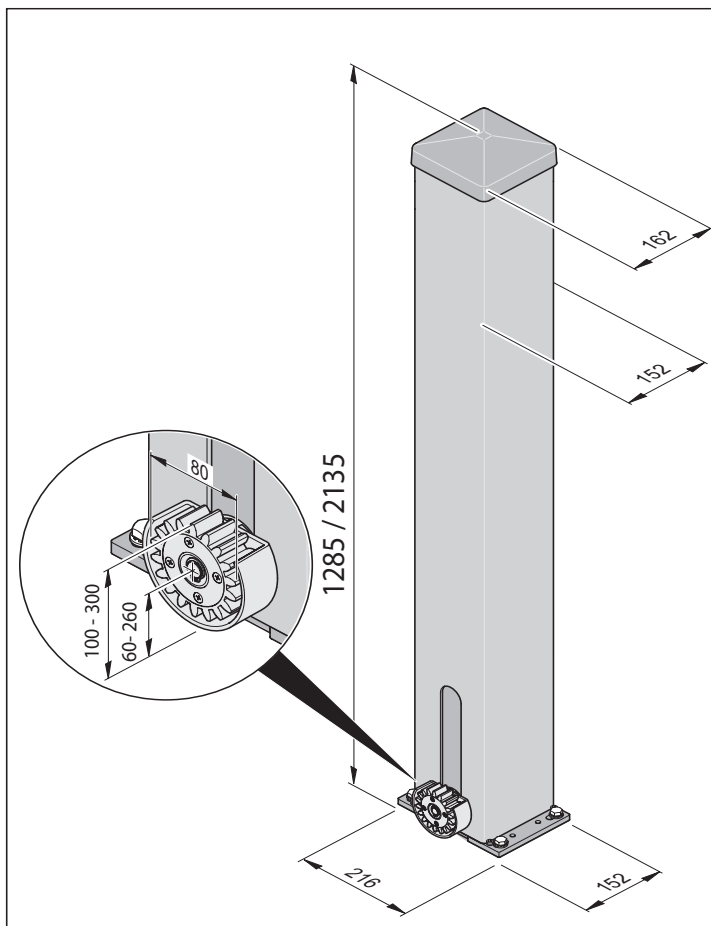

* Minimum height: 800 mm.

General Information

Declaration of Installation

for the installation of an incomplete machine
in accordance with the Machinery Directive 2006/42/EC, Appendix II, Section 1 B

SOMMER Antriebs- und Funktechnik GmbH
Hans - Böckler - Straße 21 - 27
73230 Kirchheim unter Teck
Germany

hereby declares that the drive

SP 900

in combination with the control unit

ST-B-1

as of the identification SP 900 complies with the Machinery Directive 2006/42/EC and is intended for installation in a gate system.

- The following fundamental safety requirements have been applied and observed in accordance with Appendix I:
 - General principles No. 1
 - 1.2 Safety and reliability of control units
 - Optical safety contact strip for gate OPEN direction of motion: terminal 19; 21; 23 cat 2 / PL C
 - Optical safety contact strip for gate CLOSE direction of motion: terminal 25; 27; 29 cat 2 / PL C
 - Electrical safety contact strip for gate OPEN direction of motion: terminal 19; 21 cat 2 / PL C
 - Electrical safety contact strip for gate CLOSE direction of motion: terminal 25; 27 cat 2 / PL C
 - 2-wire photo eye terminal 12; 14 cat 2 / PL C
 - 4-wire photo eye terminal 8; 10; 12; 14 cat 2 / PL C
 - STOP button terminal 20; 30 cat 2 / PL C
 - EMERGENCY STOP button terminal 15; 17 cat 2 / PL C
 - Internal force limitation Cat 2 / PL C
 - Safety categories in accordance with EN 13849 - 1:2008
- Compliant with the regulations of the EC Building Products Directive 89/106/EC.
For the operating forces part, the respective initial testing has been carried out in consultation with recognized inspecting authorities. In doing so, the harmonized standards EN 13241-1, EN 12453 and EN 12445 have been applied. For the tested combinations, refer to the "Reference list" table in the Internet under www.sommer.eu.
- Compliant with the Low Voltage Directive 2006/95/EC.
- Compliant with the Directive on Electromagnetic Compatibility 2004/108/EC.
- The technical documentation was drawn up in accordance with Appendix VII B.

The product may only be put into operation after it has been established that the gate system complies with the regulations of the Machinery Directive.

Kirchheim, 01-09-2011



A handwritten signature in blue ink, appearing to read 'Jochen Lude', written over a horizontal line.

Jochen Lude
Responsible for documents

Installation preparations

Safety instructions



NOTE!

Follow all installation directions. Improper installation may cause serious injuries.

- The mains voltage must correspond with the voltage listed on the drive type plate.
- The contacts of all devices to be connected externally must be safely isolated from the mains voltage supply according to IEC 60364-4-41.
- Wires for external devices must be installed in accordance with IEC 60364-4-41.
- The drive may only be installed, connected and commissioned by qualified technicians.
- Do not move the gate if there are people, animals or objects in the area of movement.
- Keep children, disabled persons and animals away from the gate.
- Wear safety glasses when drilling the fastening holes.
- Cover the drive during drilling to prevent penetration of dirt.



NOTE!

The foundation must be solid and stable. Only install the drive on a correctly aligned gate. An incorrectly aligned gate could cause serious injury.

- Gates must be stable in themselves, since high traction and compression forces are encountered. Reinforce lighter gates made of plastic or aluminium if necessary before installation. Ask a specialist retailer for advice.
- Remove or disable gate locks.
- Use only approved fasteners (e.g. anchor fittings, bolts). The fasteners must match the material of the ground.
- Check that the gate runs smoothly.

Tools required

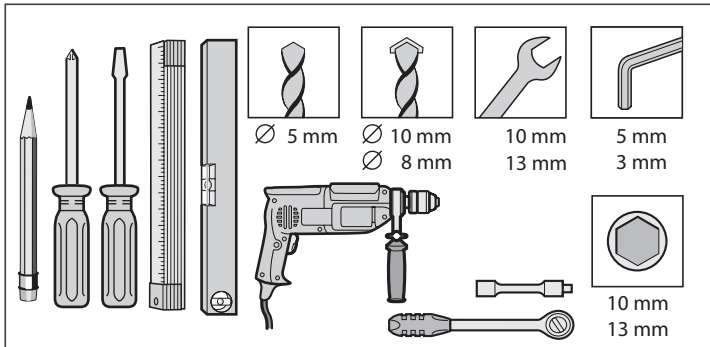

Personal safety equipment

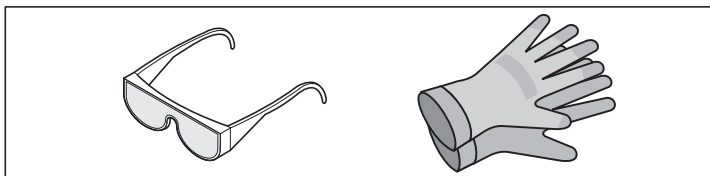

- Safety glasses (for drilling)
- Work gloves

Installation preparations

Scope of supply

- Check the package before installation to avoid unnecessary work and expense if a part is missing.
- The actual scope of supply may vary depending on the design of the drive.

Package 1

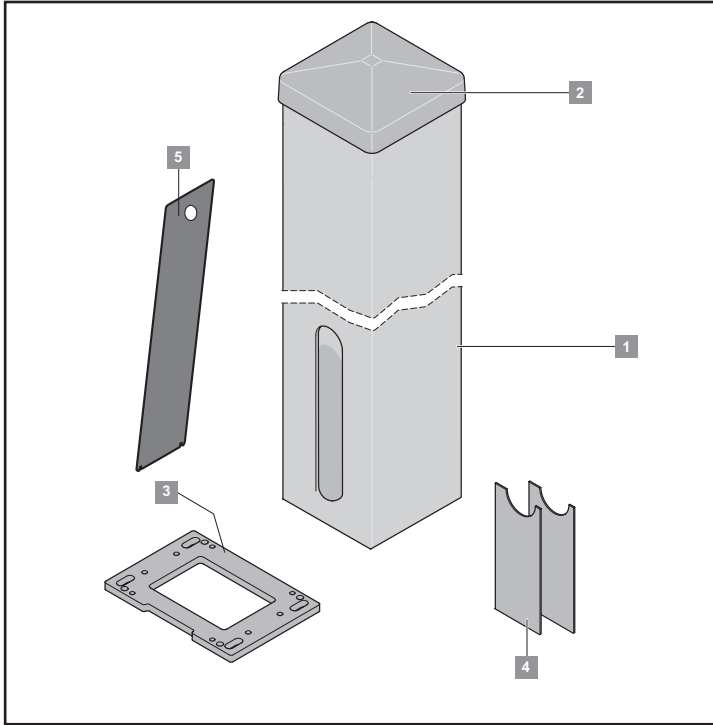

Package 1

Post 1250 mm high

Package (L x W x H)	1470 mm x 200 mm x 230 mm
Weight	11.8 Kg

Post 2100 mm high

Package (L x W x H)	2400 mm x 200 mm x 230 mm
Weight	20 Kg

1.	1 item	Post
2.	1 item	Post cover
3.	1 item	Baseplate
4.	2 items	Cover for height adjustment
5.	1 item	Revision flap

Package 2

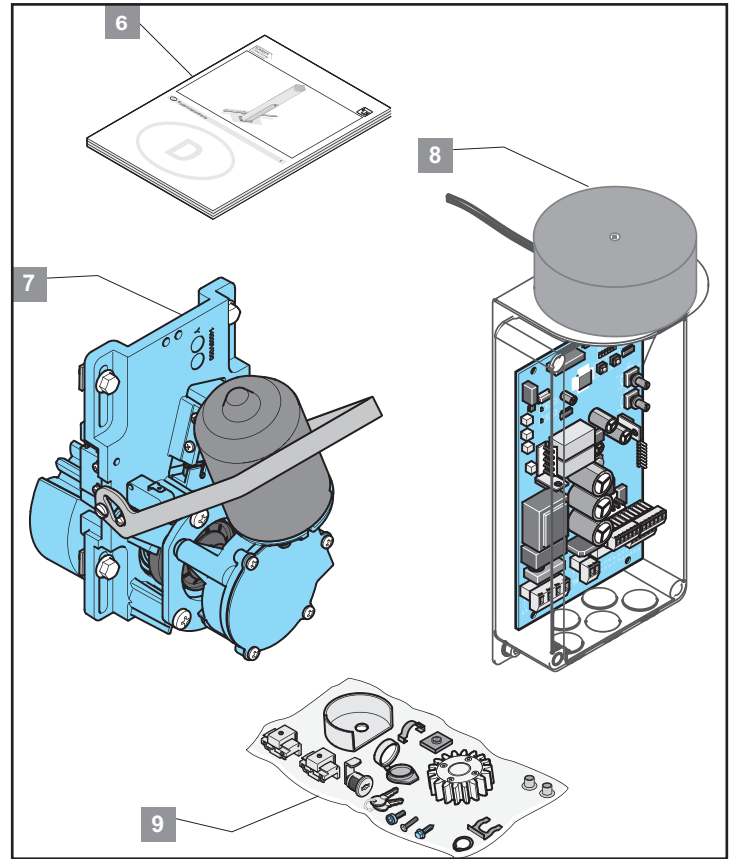

Package 2

Package (L x W x H)	800 mm x 180 mm x 155 mm
Weight	7.3 Kg

6.	1 item	Installation and Operating Instructions
7.	1 item	Operator unit
8.	1 item	Control unit with transformer
9.	1 item	Installation bag*

*no. 9 installation bag

1 item	Pinion
1 item	Plastic shield
1 item	Circlip
2 items	Screw (3.8 mm torx)
6 items	Covers
2 items	Solenoid for limit switch
8 items	Slot nut
8 items	Spring clamp
4 items	Pan head screw with hexagon socket
1 item	Lever lock
1 item	Locking clamp for lever lock
2 items	Key
1 item	Dust cap
4 items	Torx screw with fillister head (M6 x 20 mm)
4 items	Hexagon screw (M6 x 16 mm)

Installation preparations

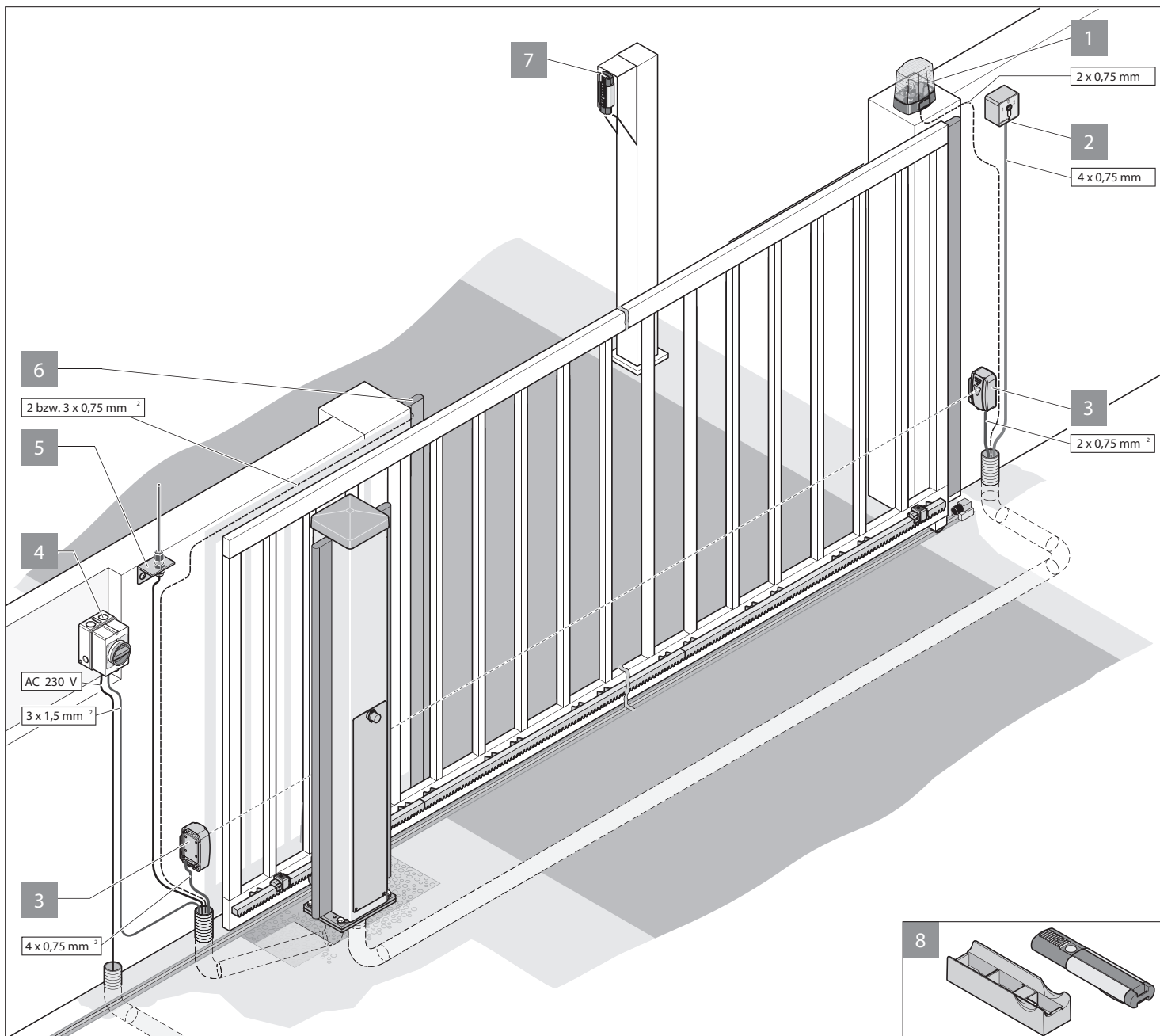

Tips for installation

- A safety device must always be connected as an NC contact so that safety is always guaranteed in case tripping or a defect.
- Determine the position of the accessories before installation together with the operator.

1.	Warning light DC 24 V, 25 W, max 0.8 A
2.	Key switch (1 or 2 contact)
3.	Photo eyes (required for automatic closing, see EN 12543)
4.	Main switch (lockable)
5.	Rod antenna (including 10 m cable)
6.	Safety contact strip (8.2 kOhm, optoelectronic safety contact strip)
7.	Telecody
8.	Car/wall holder for hand-held transmitter

General preparations

- Remove or disable all locking devices (electric lock, bars, etc.) before installing the drive.
- The gate must have a stable structure and must be suitable.
- The gate must not show excessive lateral deviation throughout its range of movement.
- The system wheels and bottom track and the roller and top guide must operate without excessive friction.
- End stops must be installed at the "gate OPEN + gate CLOSED" positions to prevent derailing of the gate.
- Install empty ducts under the gate for the cables of the mains supply line and the accessories (photo eye, warning light, key switch, etc.).



NOTE!

Additional pulse transmitters are: hand-held transmitters, Telecody, wireless indoor switches and key switches, etc. In the case of the hand-held transmitter, Telecody or the wireless indoor switches a connecting line to the drive is not required (contact your dealer).

Installation

Foundation

- The foundation must extend below the frost line (approx. 800 mm in Germany).
- The foundation must be cured and horizontal.

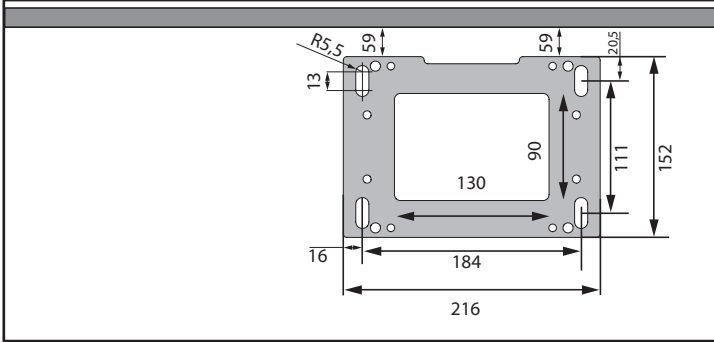

- Provide a hole in the foundation for the cables (cable outlet).

Installation of column



NOTE!
Risk of injury when drilling

- Wear safety glasses and close-fitting clothing.
- Bind long hair back.



NOTE!
Use only suitable and approved installation materials.



NOTE
Dispose of packaging according to local regulations.

Step 1: Install cover for height adjustment

Required parts:

- 1 x post (1)
- 1 x cover for height adjustment (4)

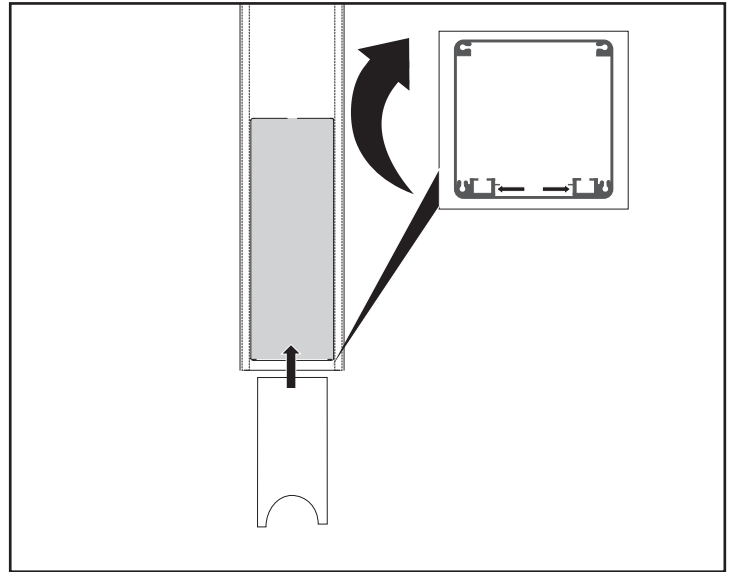

1. Carefully place column horizontally on a soft surface.
⇒ Bottom is accessible.
2. Insert cover into the inside back of the column as shown in the drawing.

Step 2: Installing the control unit

Required parts:

- 1 x Post
- 1 x Control unit (8)
- 4 x Socket head bolts (installation bag)
- 4 x Slot nuts (installation bag)
- 4 x Spring clamps (installation bag)

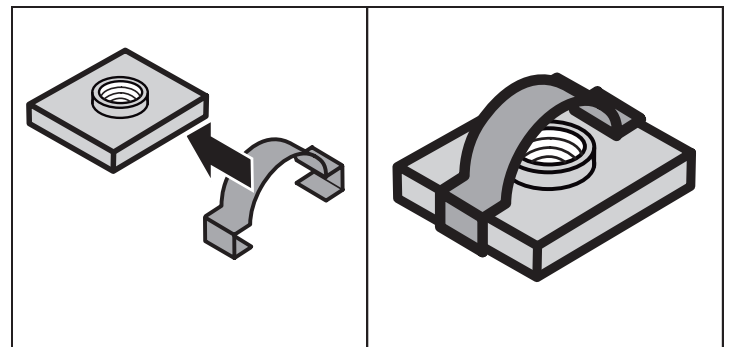

1. Slide spring clamps onto slot nut.

Installation

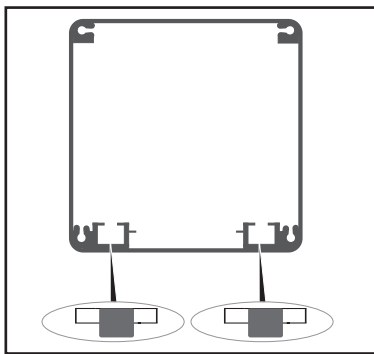

2. Insert slot nuts in C-profile on the inside back.
⇒ Note the installation direction of the slot nuts (diagram).

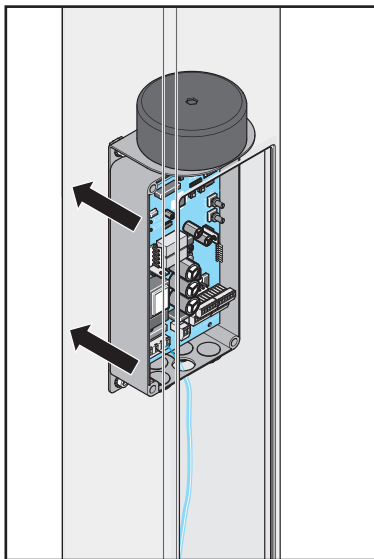

3. Insert control unit through the revision opening onto the C-profile.
4. Align control unit and slot nuts with the holes in the retainer plate exactly above the slot nuts.
5. Lightly screw in the socket head bolts and move the control unit to its subsequent position.
6. Tighten bolts.

Step 3: Installing the drive unit

Required parts:

- 1 x Post
- 1 x Drive unit (7)
- 4 x Slot nuts (installation bag)
- 4 x Spring clamps (installation bag)
- 4 x Hexagon bolts (M6 x 16)

1. Insert slot nuts into the C-profile as in step 2 (installing control unit).

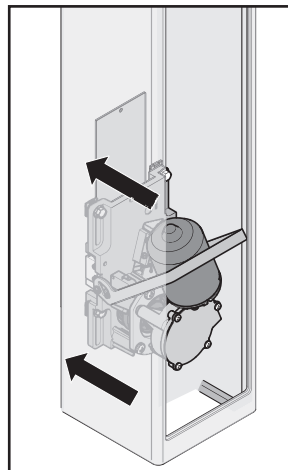

2. Install the drive unit in the same way as the control unit.

Installation

Step 4: Installing the base plate

Required parts:

- 1 x Post
- 1 x Base plate (3)
- 4 x Torx screws with fillister head (M6 x 20 mm)

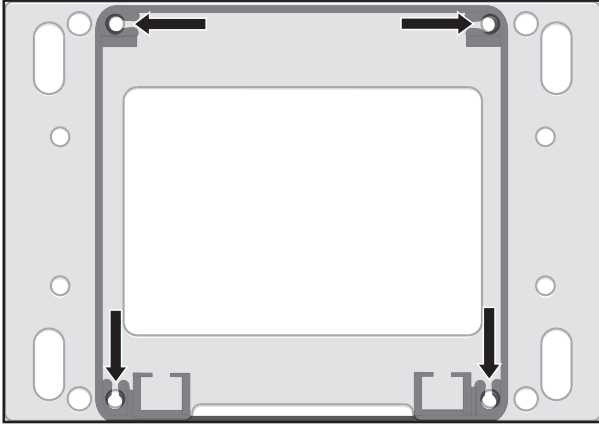

- Screw base plate to column from below as shown in the diagram.
⇒ Position the base plate with the milled groove in the direction of the gate.

- Only in the position can the screw heads be countersunk in the holes in the base plate.

Step 5: Installing the pinion

Required parts:

- 1 x Post
- 1 x Shield (installation bag)
- 1 x Pinion (installation bag)
- 1 x Circlip (installation bag)
- 2 x Screws (3.8 mm torx)

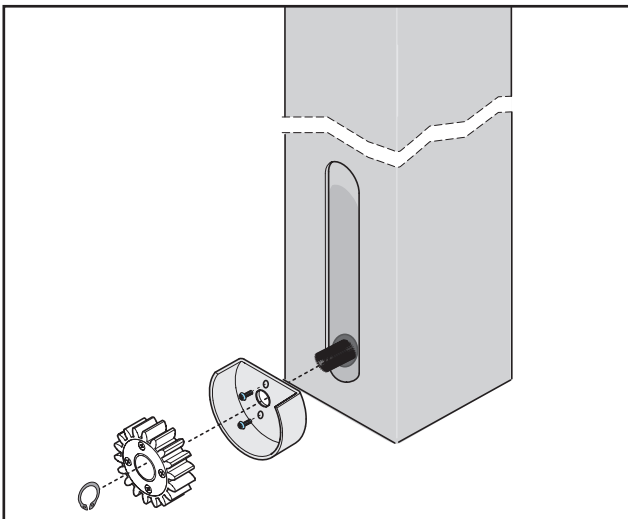

1. Position shield as shown in the diagram and screw in place.
2. Place pinion on motor shaft as shown in the diagram.
3. Lock pinion with circlip.
⇒ Use a suitable circlip pliers.

Step 6: Installing the revision flap

Required parts:

- 1 x Revision flap (5)
- 1 x Lever lock (installation bag)
- 1 x Dust cap (installation bag)
- 1 x Locking clamp for lever lock (installation bag)
- 1 x Key (installation bag)

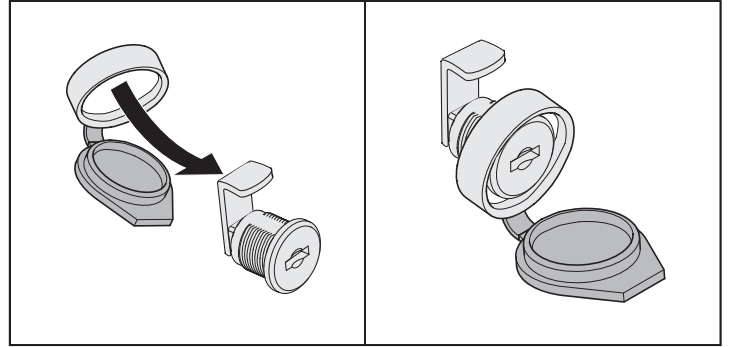

1. Assemble dust cap and lever lock as shown in the diagram.

Installation

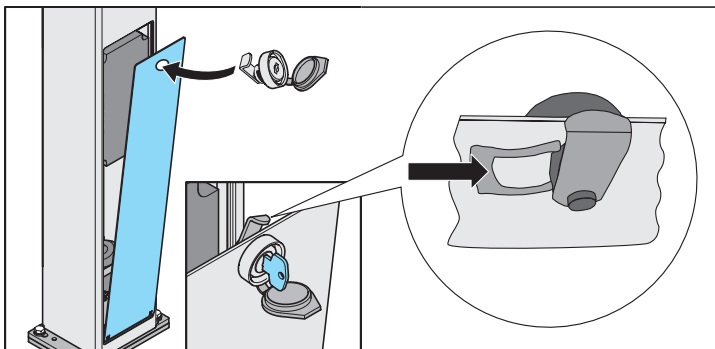

2. Connect revision flap and lock as shown in the diagram.
3. Attach lock to back of revision flap with locking clamp.
 - ⇒ Do not close revision flap yet, because additional work inside the column is required.

Installing the drive

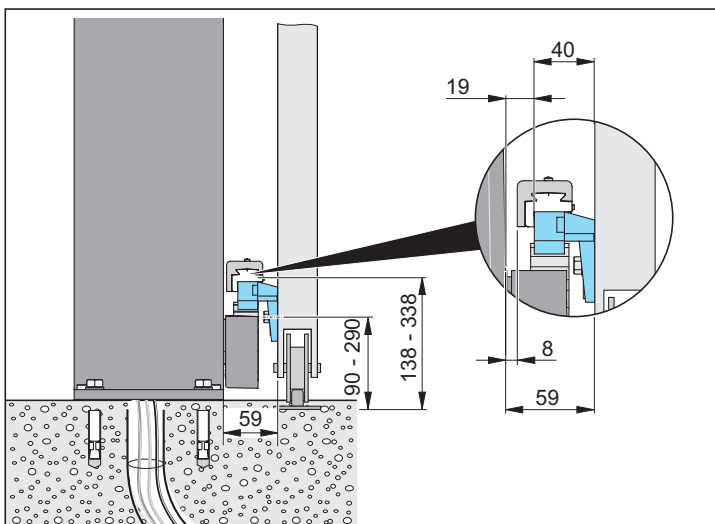

1. Place the drive on the foundation.
2. Position the drive as shown by the dimension in the diagram.
3. Mark the fixing points.
4. Define the subsequent position of the racks.
 - A second person holds a rack in the required position.

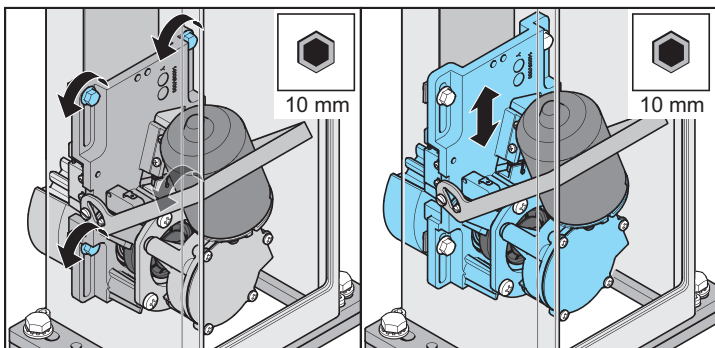

5. Unscrew the 4 external hexagon bolts (M6).
6. Push the motor unit upwards until the pinion is in contact with the rack.
7. Tighten the 4 external hexagon bolts at that position.

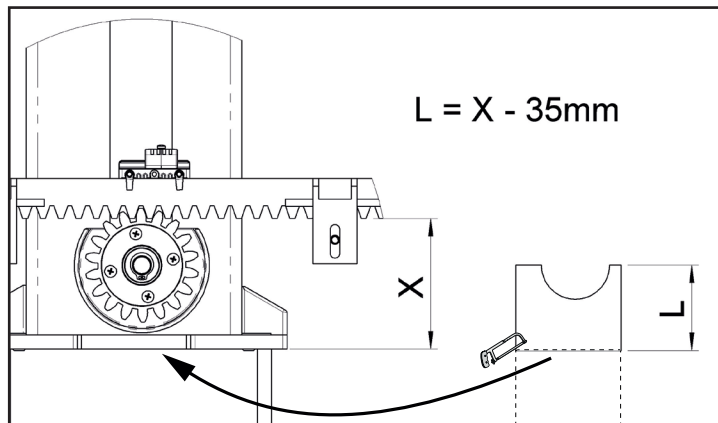

8. Measure the clearance.
 - Measure the distance between the floor (foundation) and rack.
 - ⇒ (The rack used for measurement can be placed aside for now).
 - Subtract 35 mm from the result.
 - Cut the cover plate included with the system to the calculated dimension.
9. Remove the drive from the foundation and place horizontally on a soft surface with the bottom accessible.
10. Insert the cover plate into the C-profile from below to close the opening under the pinion.
11. Drill holes in the foundation for the fastening points.
12. Replace drive on the foundation.

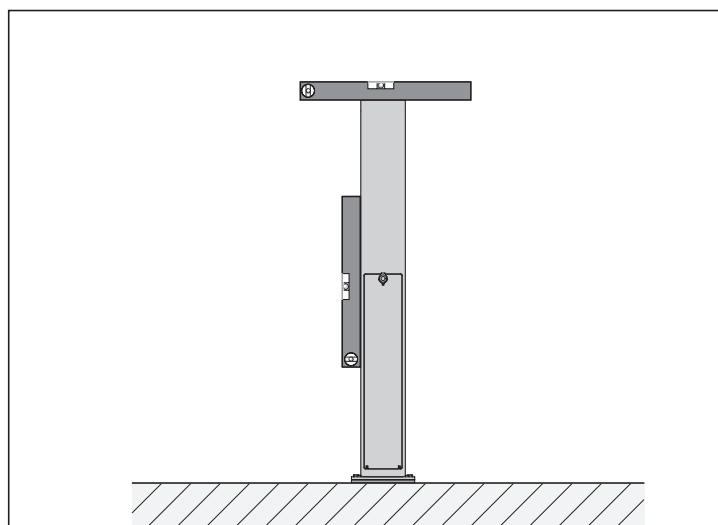

- Align column with spirit level.



NOTE

If the unevenness of the base makes it impossible to align it correctly, a levelling plate, available as an accessory, will be required.

13. Screw drive to foundation.

Installation



NOTE

Post cover must be secured to prevent removal.



NOTE

Post cover is cast aluminium.

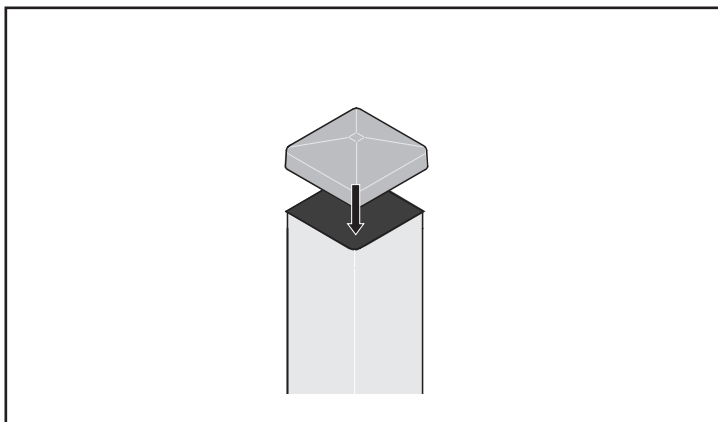

- Fasten post cover to post so it cannot be removed simply by lifting it.

Releasing drive

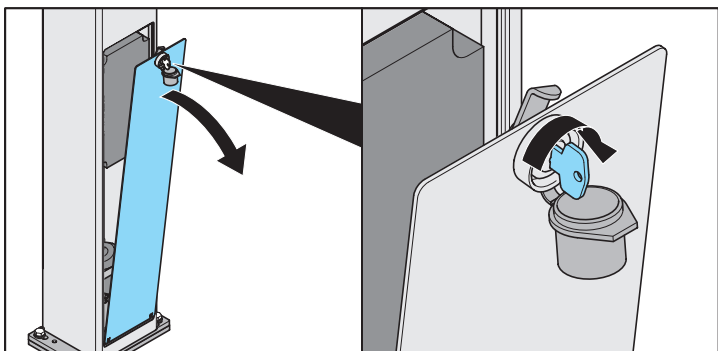

1. Open dust cap.
2. Unlock lock.
3. Open revision flap.

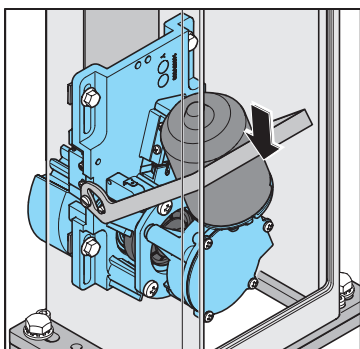

4. Push lever down.
⇒ Drive is unlocked.

Installing the racks



NOTE!

Steel racks must have a minimum width of 12 mm. Narrower steel racks may damage the drive.

- The rack must not press on the pinion at any position during operation, otherwise the gears will be damaged.
- Always start installing the rack on the passage side of the gate.

- The holes must always be marked near the pinion.

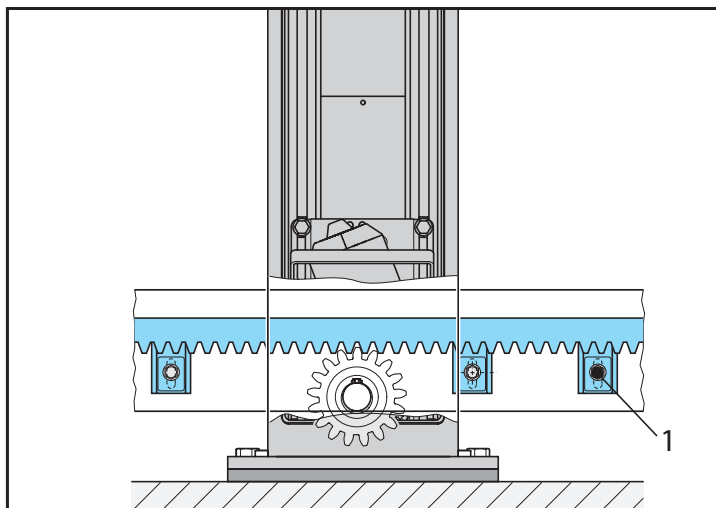
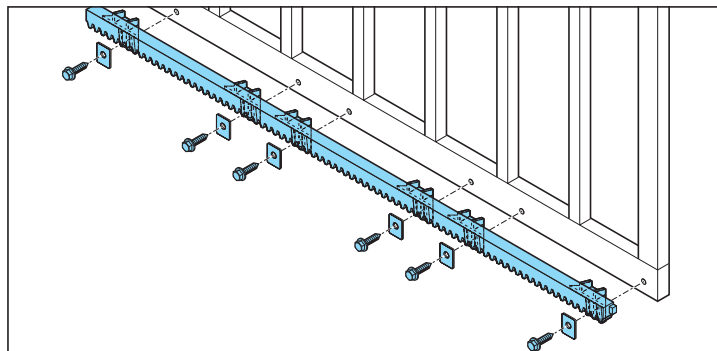

1. Before marking the first hole open the gate completely by hand.
2. Position the rack on the pinion and align it horizontally with a spirit level .
3. Mark the first hole, drill it and fasten.

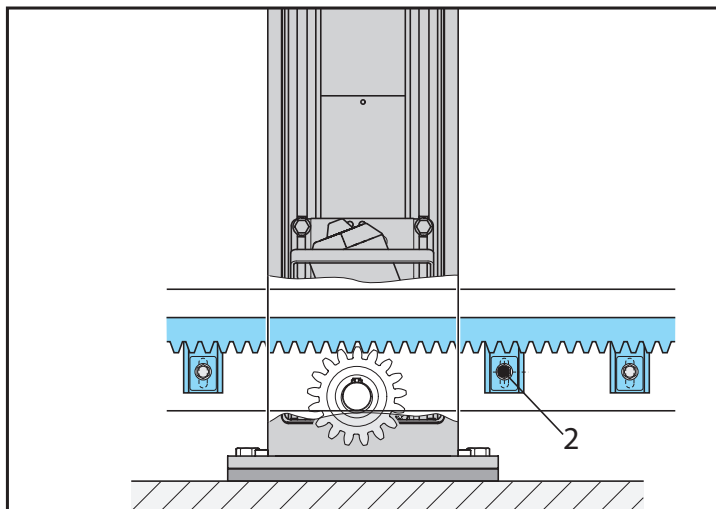

4. Slide gate towards the Closed position until the next drill point is positioned as shown in the diagram and mark the hole again.
5. Repeat until all drill positions are marked.
6. Fasten rack.

Installation

Installing additional racks



TIP!

Mark and drill the two outer holes first. Screw rack temporarily and mark the remaining holes. Then remove the rack again and drill the remaining holes. Then the rack can be finally bolted in position.

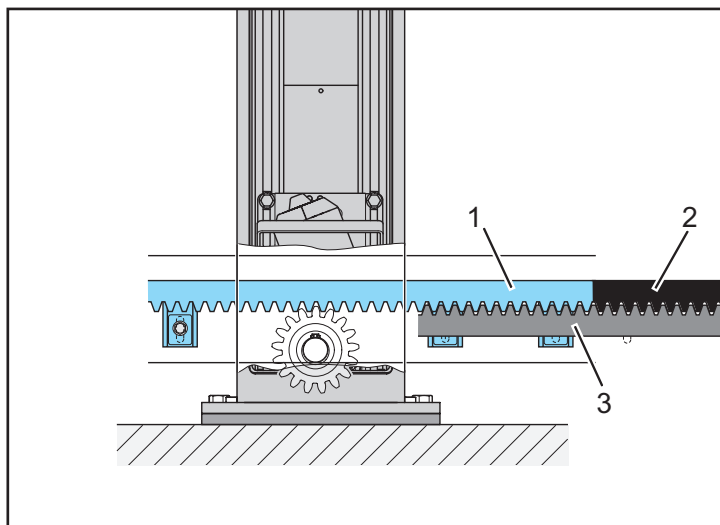

1. Position second rack (2) flush with the first rack (1) and hold another rack (3) against them from below so the teeth of the additional rack (3) mesh with the teeth of the two top racks (1 and 2). This will ensure that the second rack (2) is accurately fitted.
 - A height offset must be avoided at all times.
2. Mark and drill the holes for the second rack.
3. Attach rack.
4. Repeat this procedure for additional racks.

Adjusting tooth play



IMPORTANT!

Adjusting the tooth play compensates for minor unevenness and protects the gears.



IMPORTANT!

The weight of the gate must never rest on the motor shaft or pinion.

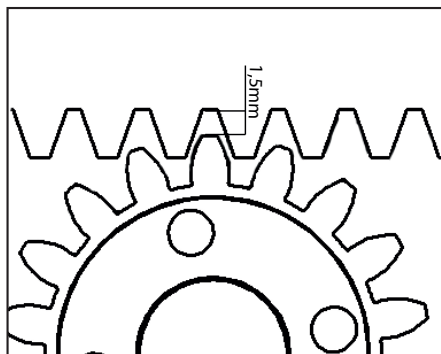

- The play between pinion and racks must be approx. 1.5 mm.

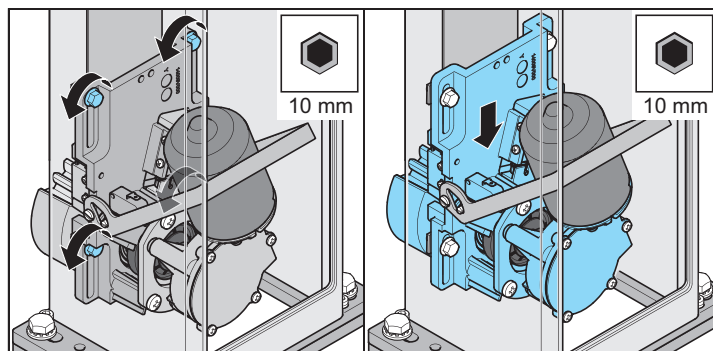

Tip! Mark the position of the motor unit before loosening the bolts

1. Unscrew the 4 hexagon bolts.
2. Adjust the height of the motor unit so the tooth play is approx. 1.5 mm.
3. Tighten the 4 hexagon bolts.

Installing clamps



NOTE

Clamps are also required for installing the high column (2100 mm).

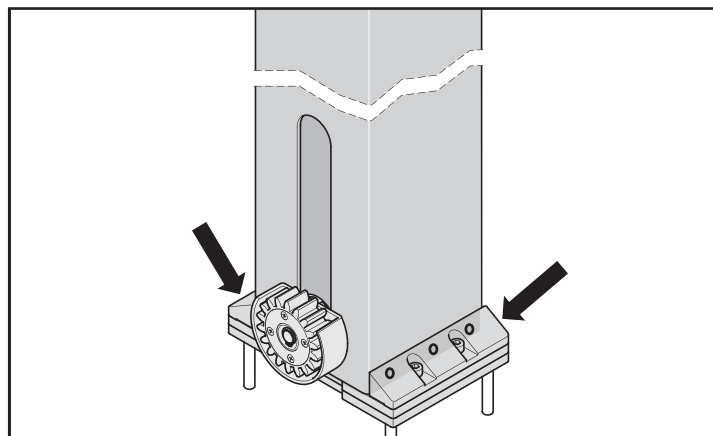

1. Fix clamps at the specified position.
 - ⇒ The column has holes.
 - ⇒ The clamps have locating pins.
2. Fasten the clamps with the 4 socket head bolts to max. 15 Nm each.

Connection

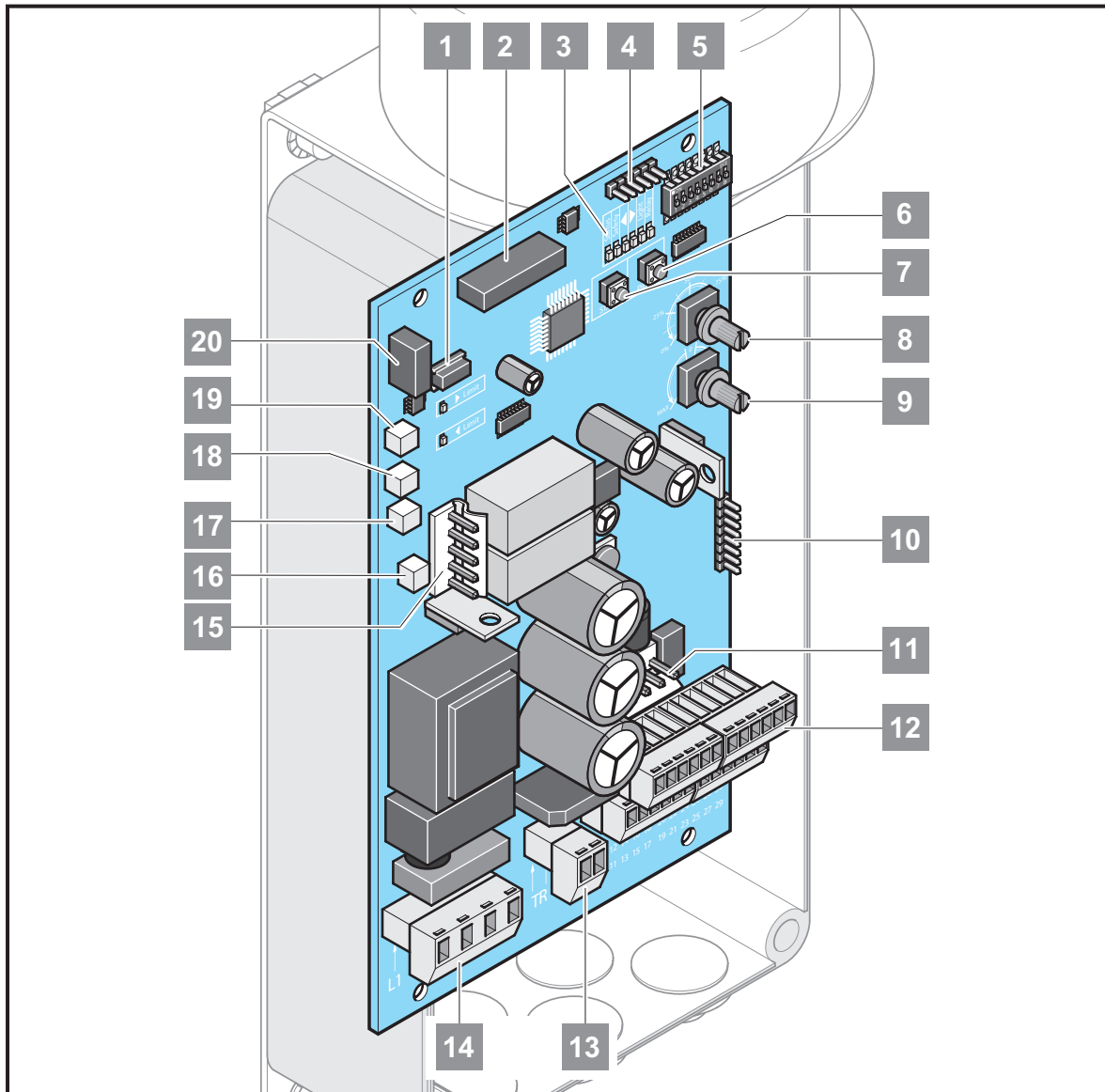

- | | |
|---|--|
| <ul style="list-style-type: none"> 1. Terminal connection 2. Slot for four-channel radio receiver 3. LEDs 4. Software update interface 5. DIP switches 6. Prog. Button 7. Start button 8. Weight setting 9. Automatic close setting 10. SOM bus 11. Battery connection 12. Connecting strip for accessories | <ul style="list-style-type: none"> 13. Secondary transformer 14. Mains connection 15. Motor connection 16. Motor lock (green) 17. Emergency release switch (red) 18. Left limit switch (blue) 19. Right limit switch (orange) 20. Connection for wireless safety contact strip (accessory) |
|---|--|

Connection

Safety instructions

- The control unit must be connected to the power supply by an electrician only.
- Ensure that the drive is securely fastened to the ground and the racks on the gate to withstand the high forces generated when opening and closing the gate.
- If a button is used for opening or closing, it must be installed within sight of the gate at a height of at least 1.6 m to prevent operation by children.
- The rack must not press on the pinion during operation, otherwise the drive will be damaged. See p. 13 "Adjusting the gear play".
- Follow the standards for installation, e.g.: EN 12604, EN 12605.



NOTE!

Set the DIP switch with a narrow and flat plastic object.
Never use a metal object.
This will damage the DIP switch.

Installation location



NOTE!

As delivered the drive is installed on the left, i.e. the gate opens to the left.



NOTE!

If a moving block with an internal rack is used, the DIP switch positions are reversed see "Setting the limit switches", sec. "Moving block with internal rack".

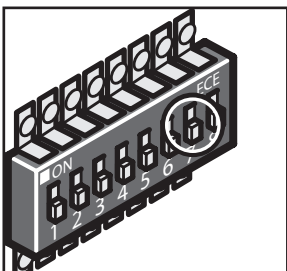
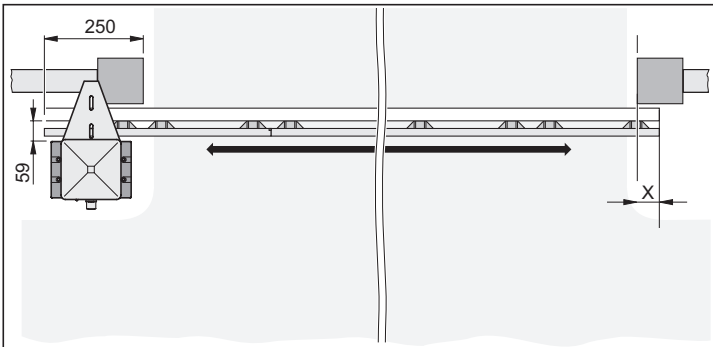

- DIP 7 OFF
⇒ Gate opens to the left.

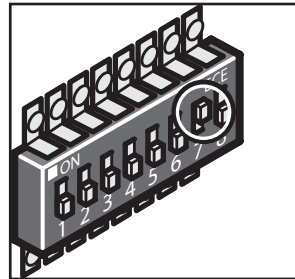
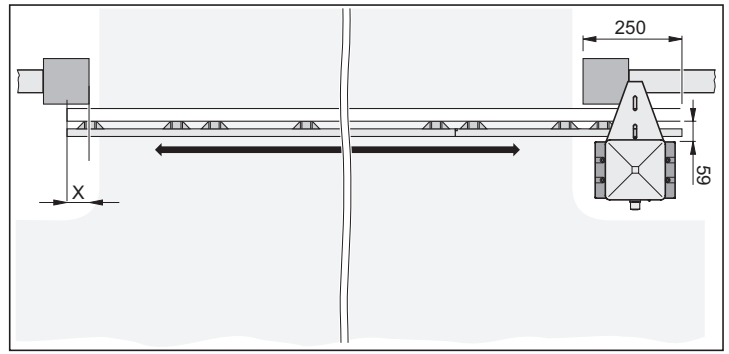

- DIP 7 ON
⇒ Gate opens to the right.

Connection

Mains connection



WARNING:

Risk of electric shock when working on live parts!
Always disconnect the complete system from the power supply before starting any electrical work.
Also unplug the battery pack.



NOTE!

The mains power cable and the cables for the solenoids (limit switches) must be installed in the right of the column.

All signal wiring must be installed in the right of the column .

- Approved cable length max. 30 m.
- Approved cable cross-section: max. 2.5 mm².

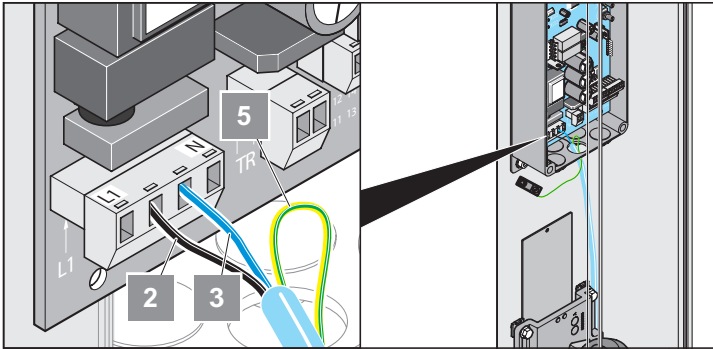

1	L1	Primary transformer line AC 220 V - 230 V
2	L (black)	Mains supply line AC 220 V - 230 V
3	N (blue)	Transformer line (neutral conductor)
4	N	Primary transformer line (neutral conductor)
5	PE (green/yellow)	The PE is run from the control unit housing and connected to the earth clamp under the control unit housing



NOTE!

Buttons and other command controls must be installed and actuated within view of the gate only.
Violation of this requirement may result in serious injury to third parties.



Note!

Connect all safety components and accessories **before** commissioning, because the control unit automatically detects and saves the connected peripherals. If additional peripherals are connected later, the control unit will need to be reset first. Then the peripherals can be connected. When it is switched on for the first time after that, the control unit detects newly connected accessories and the system can be operated again.

Connecting safety devices



PLEASE NOTE!

The system must be disconnected from the power supply before any work on the gate or drive.
Also unplug the battery pack.



PLEASE NOTE!

The emergency stop button must used for the specified purpose only.

Emergency stop button (normally closed contact)

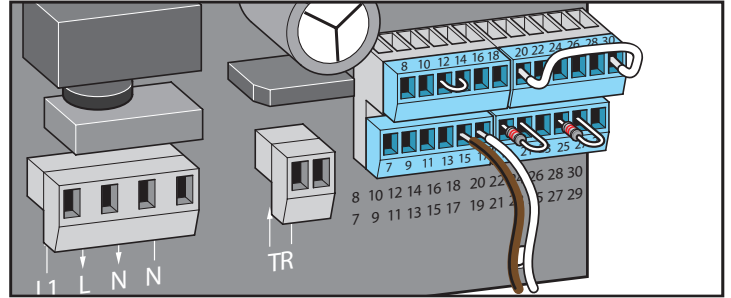

Terminals:

- 15 Normally closed contact
- 17 Normally closed contact

Safety contact strips

8.2 K Ω (OPEN)

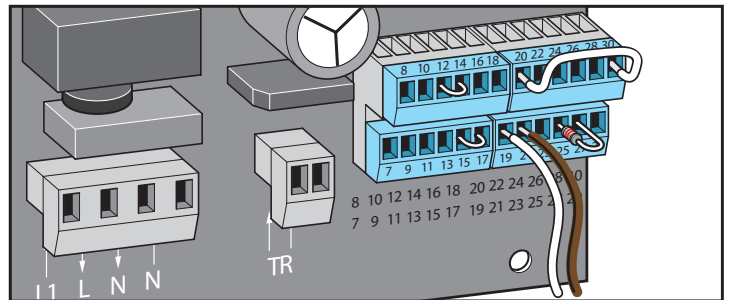

Terminals:

- 19 GND
- 21 Signal

8.2 K Ω (CLOSED)

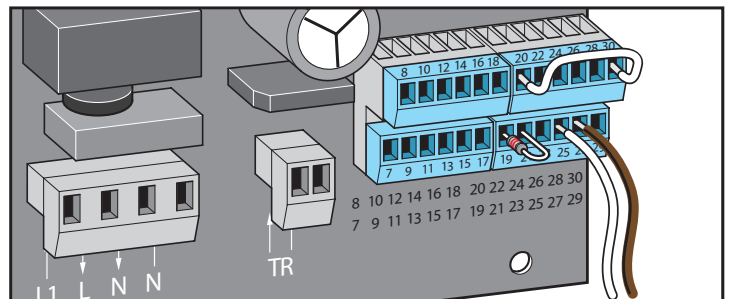

Terminals:

- 25 GND
- 27 Signal

Connection

Optoelectronic safety contact strip (OPEN)

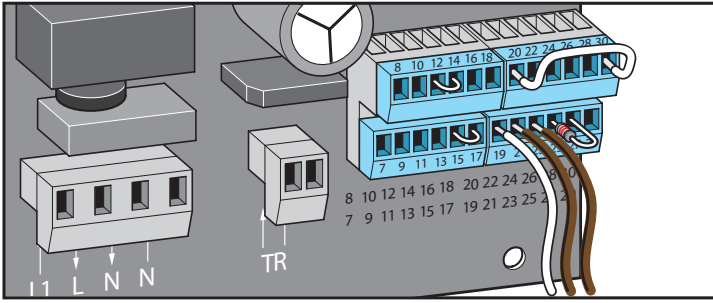

Terminals:
 19 GND
 21 Signal
 23 +12 V

Optoelectronic safety contact strip (CLOSED)

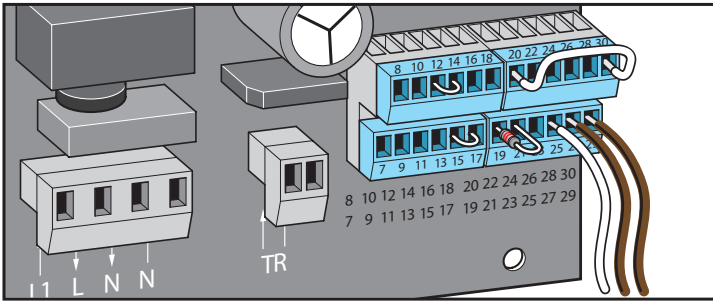

Terminals:
 25 GND
 27 Signal
 29 +12 V

2-wire photo eye (bus system)

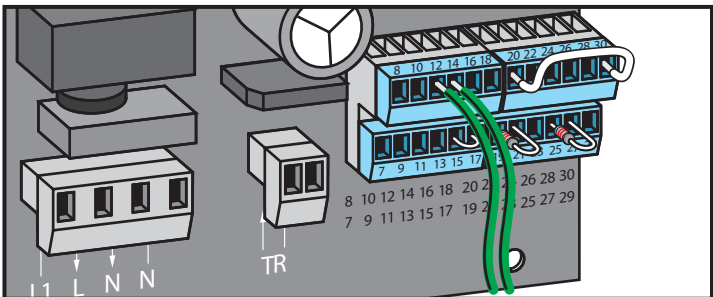

Terminals:
 12 NC
 14 COM



Note!

The polarisation is irrelevant for connection!

4-wire photo eye



PLEASE NOTE!

If an external device that is used only during movement operation is powered from the +24V output (e.g. card reader), power-saving mode must be disabled. See "Standby mode".

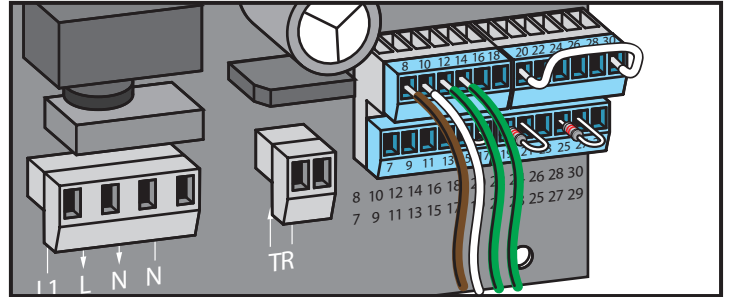

Terminals:
 8 +24V; max. 400 mA
 10 0 V
 12 NC
 14 COM

Warning light

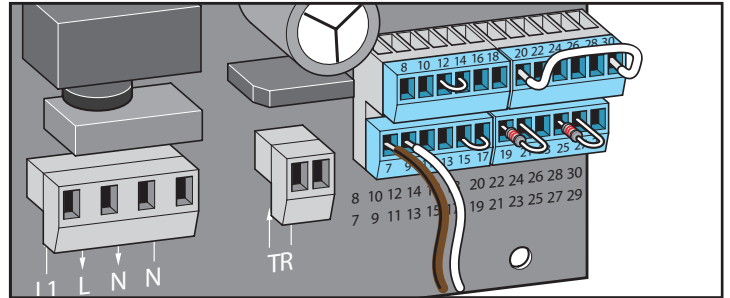

Terminals:
 7 24 V (unregulated), max. 25 W
 9 GND



NOTE!

The control unit automatically generates the flashing warning light.

Connection

Connecting button



NOTE!

Connect button only!
Do not use locking switches, because continuous signals cannot be processed.

Pulse button

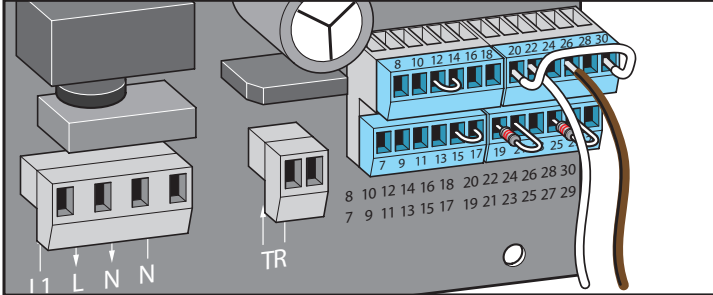

Terminals:

22 GND
26 Signal

Defined opening and closing



PLEASE NOTE!

Which button has which function must be clearly labelled.

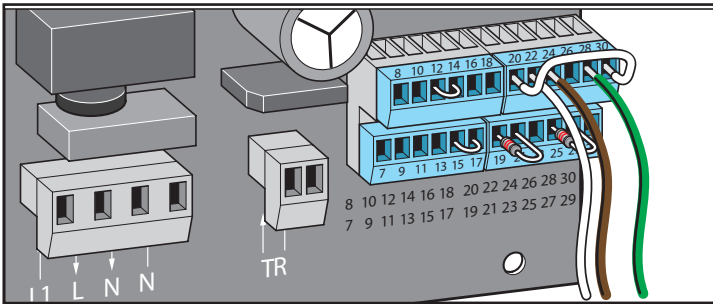

Terminals:

22 GND
24 OPEN input (normally open contact)
28 CLOSED input (normally open contact)

Partial opening

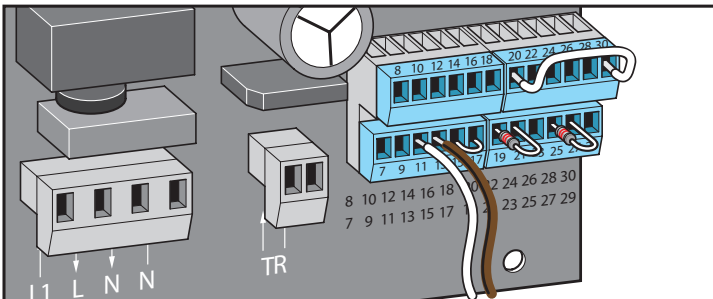

Terminals:

11 GND
13 Partial opening

Stop button



Note!

Remove jumper

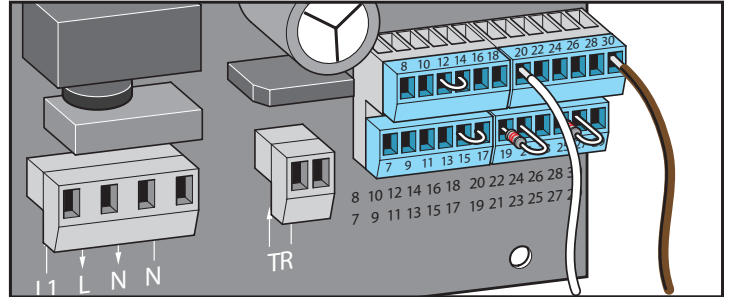

Terminals:

20 GND
30 STOP input (normally closed contact)

Connection / Commissioning

Open-Stop-Close button

PLEASE NOTE!
Which button has which function must be clearly labelled.

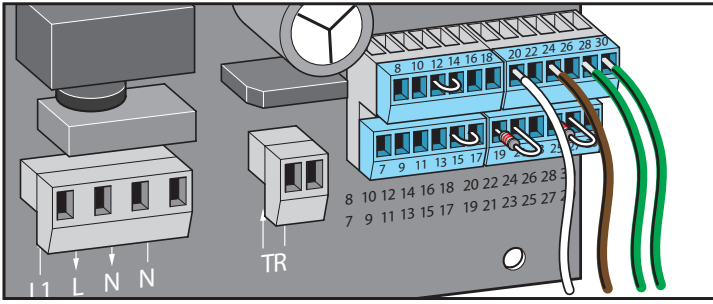

Terminals:

- 20 GND
- 24 OPEN input (normally open contact)
- 28 CLOSED input (normally open contact)
- 30 STOP input (normally closed contact)

Potential-free relay contact

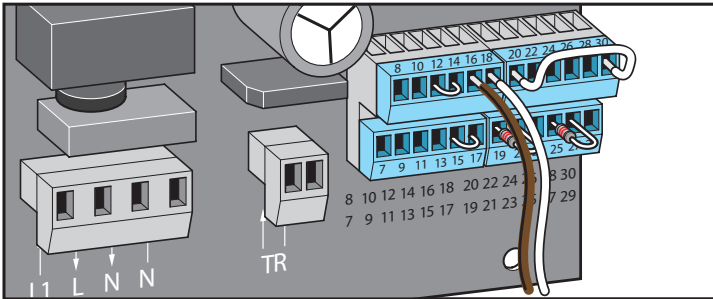

Terminals:

- 16 ; 18 max. 24 V DC or AC; max. 1 A

Optional connections

PLEASE NOTE!
The system must be disconnected from the power supply before any work on the gate or drive.
Also unplug the battery pack.

Radio-based safety contact strip

Connect radio receiver to board

PLEASE NOTE!
The system must be disconnected from the power supply before plugging in the radio receiver.
Also unplug the battery pack.

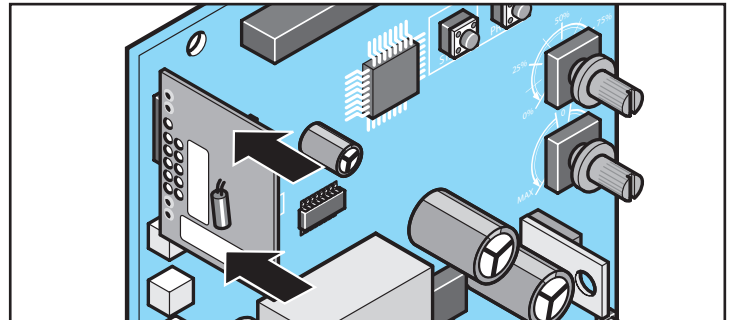

1. Connect the receiver board to the control unit as shown in the diagram.

i **NOTE!**
The maximum runtime for a gate movement when using a radio-based safety contact strip is reduced to 80 seconds for safety reasons.

i **NOTE!**
For information on connection, settings etc., see the separate instructions for the radio-based safety contact strip.

Connection / Commissioning

Battery pack



PLEASE NOTE!

Installation and inspection of the battery pack may only be performed by a qualified electrician.



PLEASE NOTE!

The system must be disconnected from the power supply before working on the drive. Also unplug the battery pack.



PLEASE NOTE!

The battery pack is not suitable for use on lifting gates.



PLEASE NOTE!

Use only an original battery pack approved by SOMMER Antriebs- und Funktechnik GmbH.



NOTE!

The general requirements for working with batteries (see instructions for battery pack) must be observed.

1. Disconnect the system from the power supply.

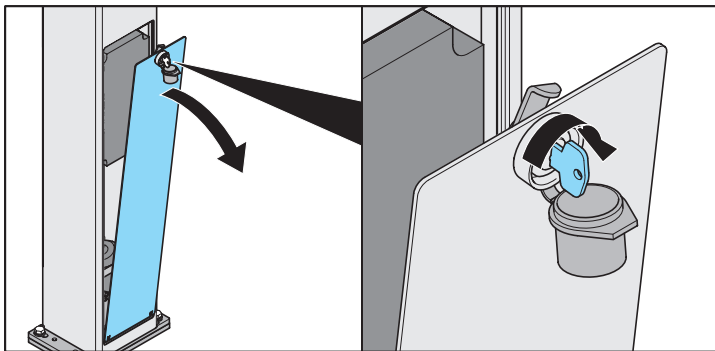

2. Open revision flap.

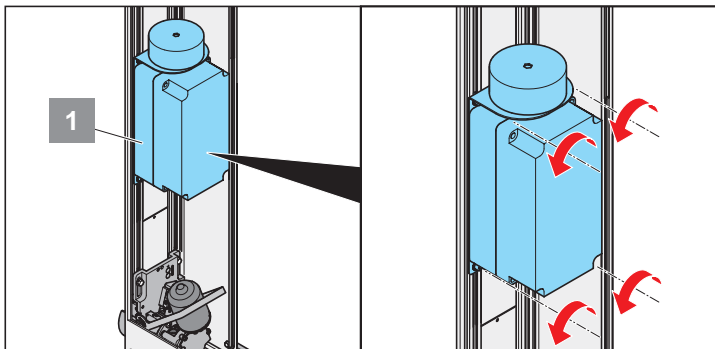

3. Unscrew the 4 screws on the control unit (1).

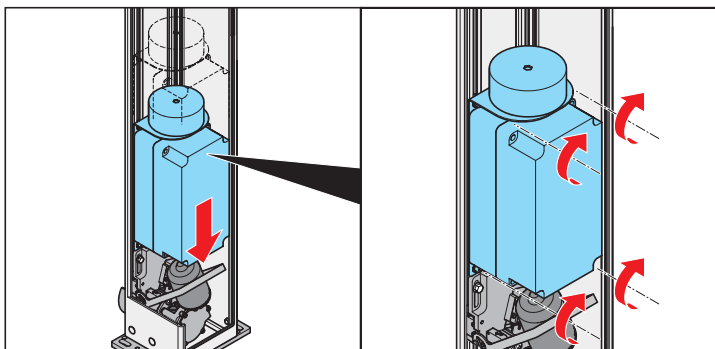

4. Lower the control unit approx. 150 mm and fix in place again.

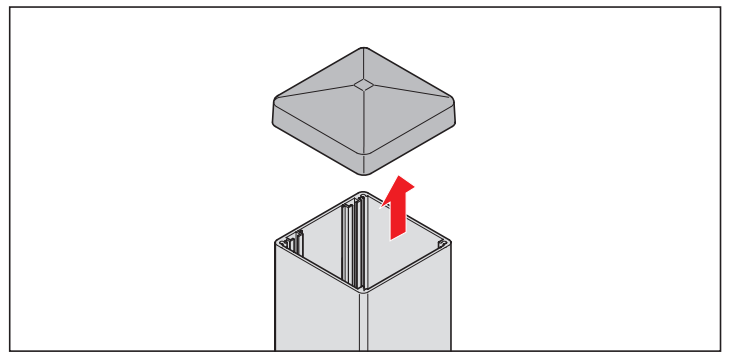

5. Remove the post cover.

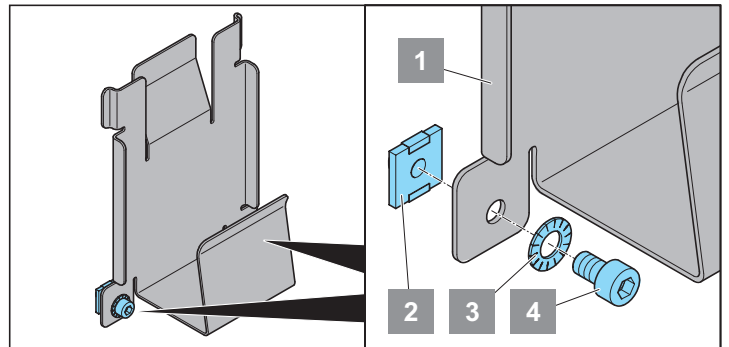

6. Prepare base plate (1) for installation.

- ⇒ Insert screws (4) through the washers (3) and the fastening holes.
- ⇒ Rotate slot nuts (2) from the opposite side to the screws (do not tighten yet).

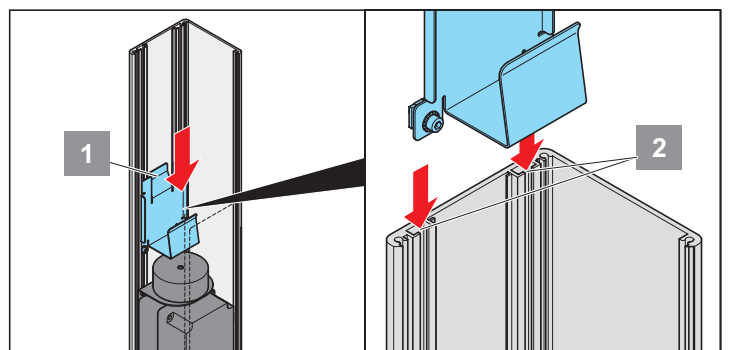

7. Insert installation plate (1) from above into the post profile (C-profile) (2) and push down.

- ⇒ The installation plate has been correctly inserted in the post if the guide nose (1) runs between the two C-profiles (2).

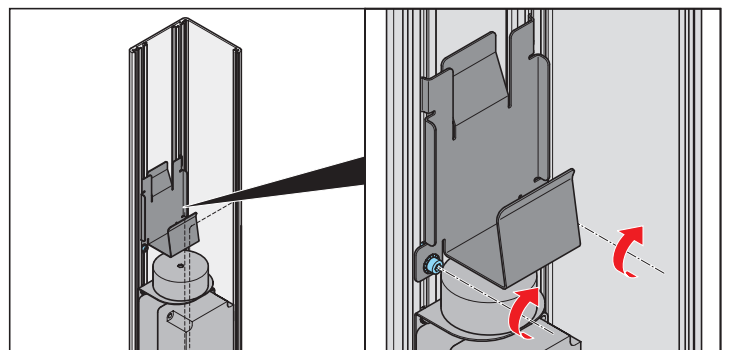

8. Position the installation plate and tighten the screws.

- ⇒ The installation plate is correctly positioned if it is immediately under the control unit transformer (see diagram).

Connection / Commissioning

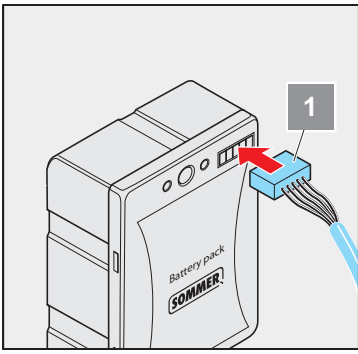

9. Plug connector cable into the battery pack (1).

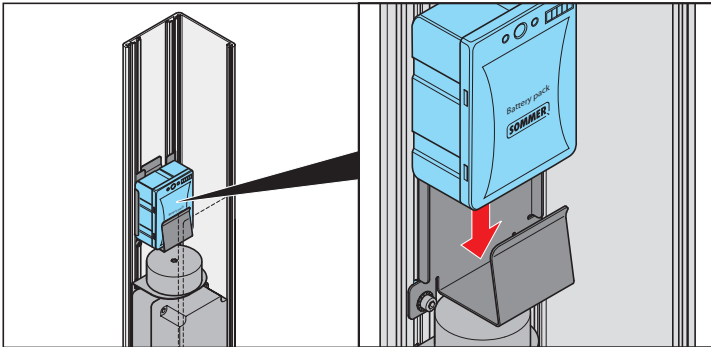

10. Place battery pack on the installation plate.

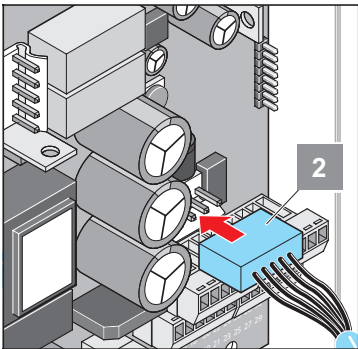

11. Remove control unit cover and plug the other end of the connector cable into the control unit (2).

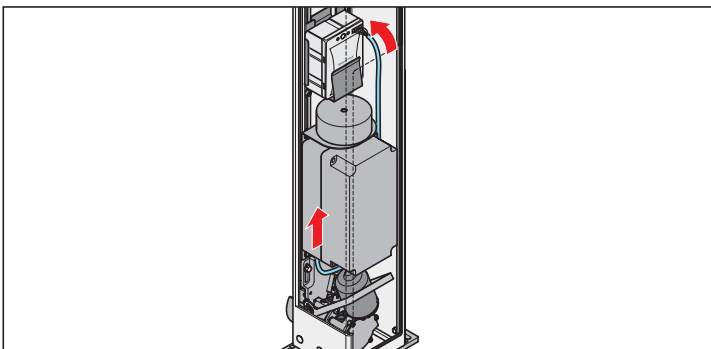

12. Replace the cover.

⇒ Make sure that the connector cable is positioned as shown in the diagram.

⇒ If necessary, push the control unit up slightly.

13. Connect main power.

Test run

1. Run a complete cycle with mains power (gate OPEN and gate CLOSE).
2. Start a new cycle and disconnect the mains power during the cycle.
 - ⇒ Battery pack is detected and activated.
3. Restore mains power.

External antenna

- If reception is inadequate with the radio receiver internal antenna, an external antenna can be connected.
- The antenna cable may not exert any mechanical force on the radio receiver; provide for stress relief.
- Define the installation location together with the operator.

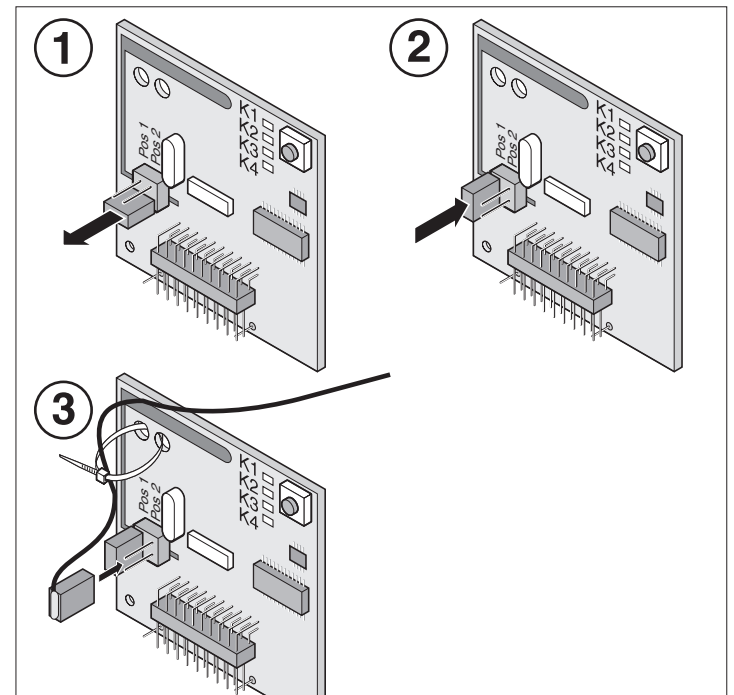
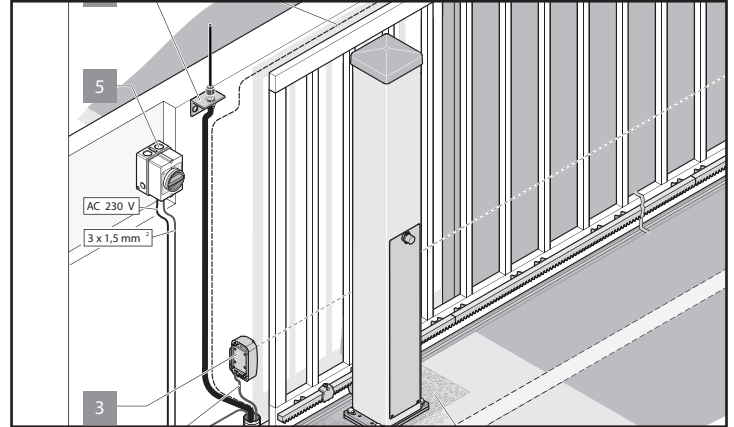

1. Pull jumper from pins.
2. Place jumper in "Pos 1".
3. Place external antenna jumper at "Pos 2".

i **NOTE!**
Follow instructions for external antenna.

Commissioning / Operation

Safety instructions



NOTE!

After installation of the drive, the person responsible for the installation must complete an EC declaration of conformity for the gate system in accordance with Machinery Directive 2006/42/EC and apply the CE mark and a type plate. This is also required for private installations and also if the drive is retrofitted to a manually operated gate. This documentation and the Installation and Operating Instructions are retained by the operator.



NOTE!

The commissioning sequence described below is important. All safety components and accessories connected to the control unit are automatically detected by the control unit when it is switched on and its correct function is tested. If peripherals are connected later, the control unit must be reset before the drive can be operated again.

Adjusting gate weight



NOTE!

The gate weight must be precisely adjusted. If the setting is not correct, the operating forces will be too high and the power shut-off will be too late. Severe injuries may result.

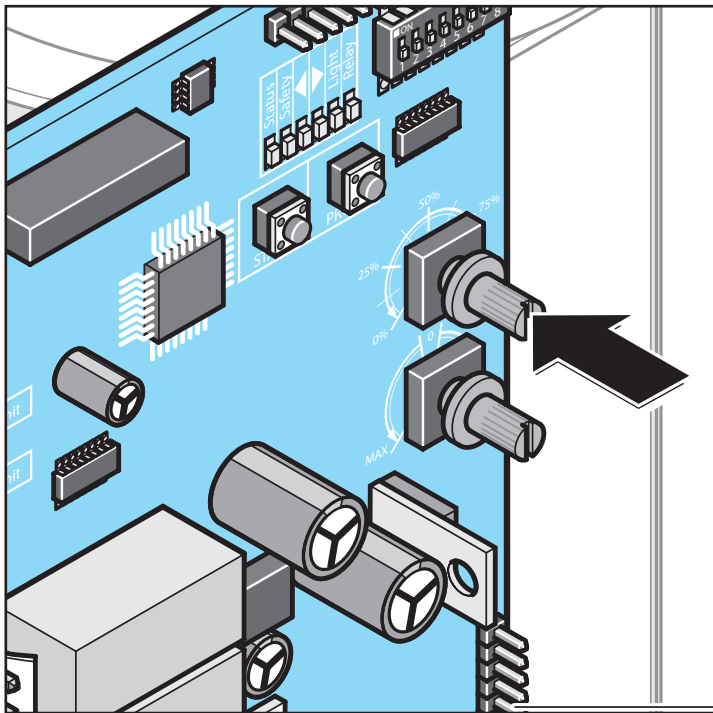

Gate weight	Setting
400 kg	100%
300 kg	75%
200 kg	50%
100 kg	25%

Locking weight potentiometer



IMPORTANT NOTE!

(1) After adjusting the gate weight, DIP switch 3 must be set to ON immediately.

This prevents the weight adjustment and other parameters important for safe operation of the system from being accidentally changed.

(2) In addition, after setting the DIP switch (3), pull out the rotary button of the weight potentiometer and place in the immediate vicinity of the drive.

The rotary button must never be pulled out before activation of the write protection, because the setting here can also be changed accidentally.

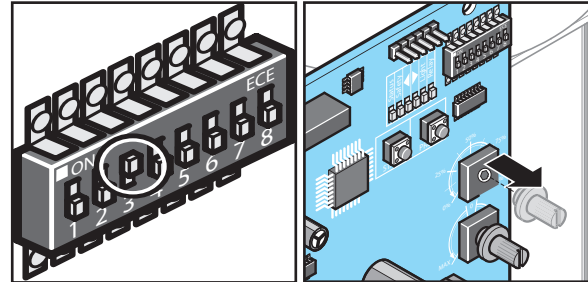

Connecting the power supply

Connect the power supply of your drive.

Switch on drive

Switch on the drive at the main switch.

Commissioning / Operation

Installing limit switches



NOTE!

The limit switches contain strong magnets!

Strong magnetic fields may interfere with some medical devices such as pacemakers!
Do not place magnets close to such devices!

In case of doubt, consult the manufacturer of the device.

Set left end position

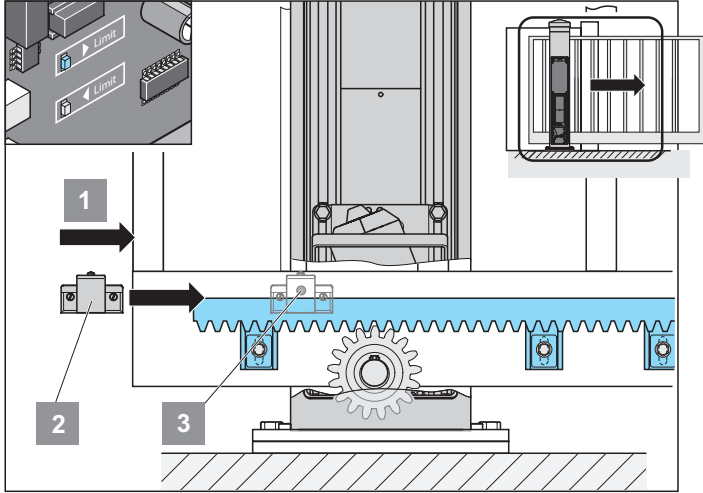

1. Make sure that the drive is unlocked.
2. Push gate to the left end position (1).
3. Push the limit switch magnet (2) to the sensor (3) until it switches (the LED ◀ on the control unit lights up).
4. Tighten limit switch magnet 2.

Set right gate end position

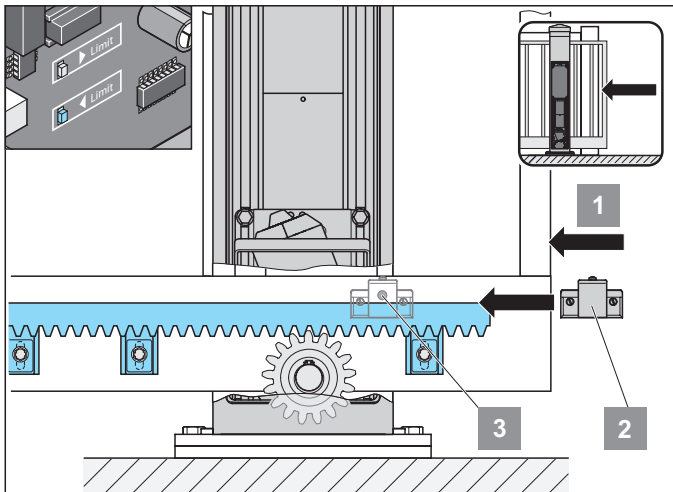

1. Push gate to the right end position (1).
2. Push the limit switch magnet (2) to the sensor (3) until it switches (the LED ◀ on the control unit lights up).
3. Tighten limit switch magnet 2.



NOTE!

Fine adjustment.

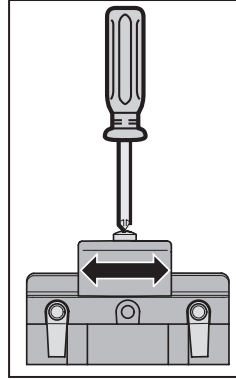

1. Loosen screw.
2. Adjust switching magnet.
3. Tighten screw.

Install limit switch and adjust end positions with a rectangular rack cover



NOTE!

The rack cover cannot be procured from SOMMER as an accessory!



NOTE!

If a rectangular cover is installed on the rack, the limit switches must be attached to the cover.

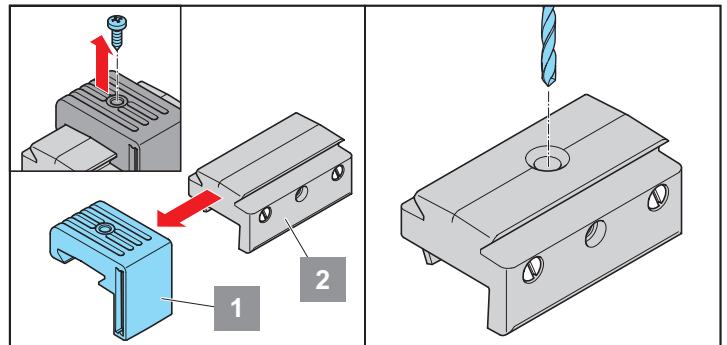

1. Unscrew screw on top section (1) of the solenoid holder.
2. Pull top section off to the side.
3. Drill a hole in the bottom section (2) of the solenoid holder for screwing it to the rack cover and smooth the hole thoroughly.

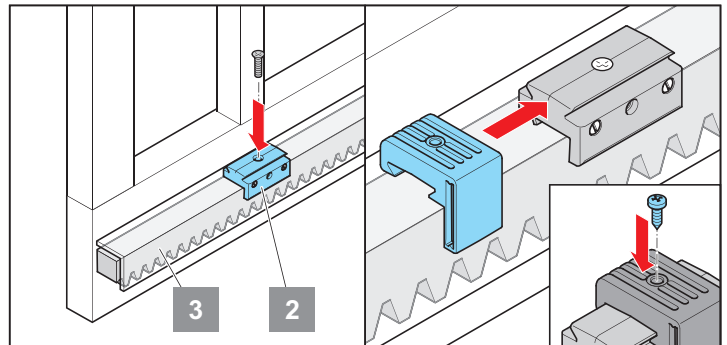

4. Screw the bottom section (2) of the solenoid holder to the rack cover at the required position (3).

Commissioning / Operation

5. Push the top section (1) of the solenoid cover onto the bottom section (2), perform the fine adjustment (see note on "fine adjustment") and screw it in position.

Adjust limit switch when using a moving block with internal rack

i **NOTE!**
Not available from SOMMER as an accessory!

i **NOTE!**
Because another pinion acts to transfer the movement of the motor to the rack when a block is used, the direction of motion of the gate is reversed. This means that the limit switches on the board must be reversed.

Optional: Operation of a moving block with internal rack:

! **NOTE!**
DIP switch position of DIP switch 7 is reversed here! (see "Installation location")
After installation immediately test all safety devices (e.g. photo eye in CLOSED direction and safety contact strips in both directions) to ensure that they are operating correctly!

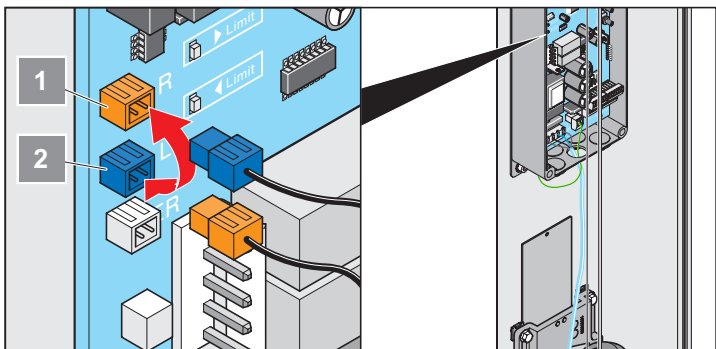
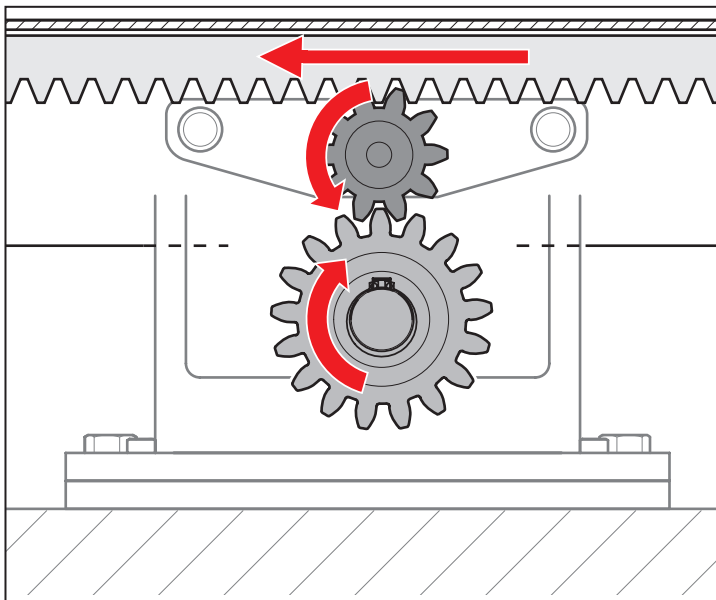

1. Open control unit housing.
2. Pull off the two blue and orange limit switch wires.
3. Connect the limit switch wire with the orange plug to the blue socket (2).
4. Connect the limit switch wire with the blue plug to the orange socket (1).

Locking drive

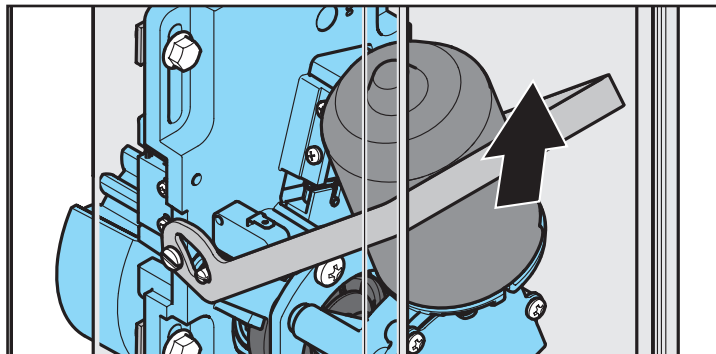

1. Push locking lever upwards.
⇒ Drive is locked. The gate can only be moved by motor.
2. Switch on main switch.
⇒ LED (Status) on.

Rest control unit

⇒ Power must be connected.

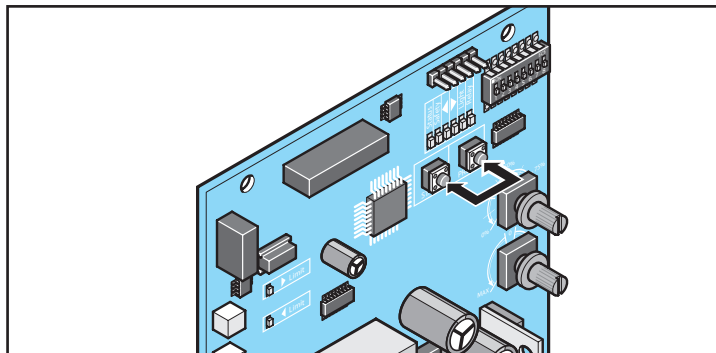

1. Press and hold "Start" and "Prog" simultaneously.
⇒ Light LED starts flashing.
2. Release buttons when light LED remains steady.
⇒ Reset completed successfully.

Programming

! **NOTE!**
The forces are programmed exclusively in dead man operation. In dead man operation there is no power cut-off, but only overload cut-off. Persons and animals must never be within the range of motion of the gate when dead man operation is active. Serious crushing injuries may be caused if this precaution is not observed.

Dead man operation see "Operating modes".

Commissioning / Operation



NOTE!

Once programming has been started, it cannot be interrupted and restarted at a later time. If programming is interrupted, it must be restarted and completed from the beginning.

The light LED flashes during programming (in general three complete cycles from one to the other end position). The light LED remains steady if the gate remains stationary between cycles.

On completion of programming the LED switches off.



NOTE!

The gate must be in the centre position when starting programming.
The gate must move in the OPEN direction when a button (start or external button) is pressed for the first time.

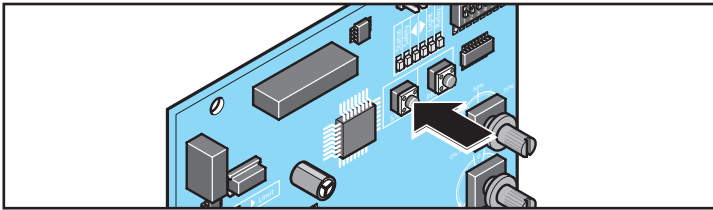

1. Move gate manually to centre position.
2. Press and hold the start button on the control unit or external hand-held control until the gate OPEN end position is reached.
⇒ Programming starts in dead man operation.
3. Press and hold the start button on the control unit or external hand-held control until the gate CLOSED end position is reached.
⇒ This was the programming movement for path measurement. It is run at reduced speed (creep mode).
4. Press and hold the start button on the control unit or external hand-held control until the gate OPEN end position is reached.
⇒ This was the programming movement for force measurement in gate OPEN.
5. Press and hold the start button on the control unit or external hand-held control until the gate CLOSED end position is reached.
⇒ This was the programming movement for force measurement in gate CLOSED.
 - When the light LED goes out,
 - ⇒ Programming is complete.
 - If the light LED remains on,
 - ⇒ Repeat the procedure until the LED is out.

Checking the force tolerance



NOTE!

Rubber safety strips must be used on the main and auxiliary closing edges. No sliding gate without safety strips may be used!

- ⇒ Our program contains various safety strips, both active (triggers an immediate stop of the gate at contact) and passive (takes up part of the inertial mass of the moving gate). This strip can be ordered from a SOMMER dealer under Art. No. 3652V000.

See also "Maintenance and care / regular testing" for more information about safety strips.

Test run:

1. Close gate.
2. Press button (1) once.
Gate opens to gate OPEN end position.

3. Press button (1) once.
The gate closes until the gate CLOSED end position is reached.
4. If one of the programmed gate end positions is not reached (gate OPEN or CLOSED), check that the correct gate weight is set on the potentiometer.
⇒ Correct if necessary.

Safety instructions

- The local safety regulations for the system must be complied with to ensure safe operation. Information is available from electrical utility companies, VDE (Association for Electrical, Electronic & Information Technologies) and professional associations.
- The operator is not protected against interference caused by other telecommunications equipment or devices (e.g. wireless systems which are being operated properly in the same frequency range).
- Replace the hand-held transmitter unit's batteries if you experience reception problems.

Radio receiver



PLEASE NOTE!

The radio receiver must be connected or disconnected from the control unit only if the control unit is disconnected from the power supply. If the drive is operated by battery, it must also be disconnected from the control unit.

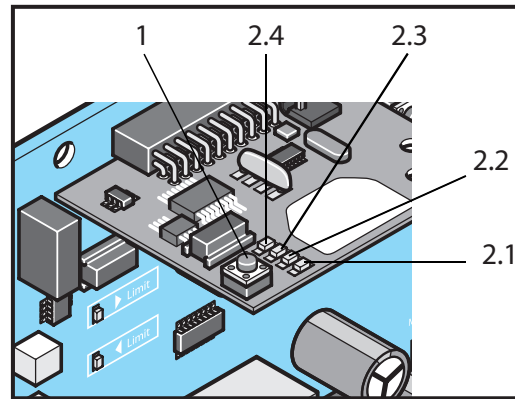

1. Learn button
- 2.1 LED channel 1
- 2.2 LED channel 2
- 2.3 LED channel 3
- 2.4 LED channel 4

Explanation of radio channels

Channel 1	Pulse mode
Channel 2	Partial opening
Channel 3	Defined OPEN
Channel 4	Defined CLOSE or pot.-free relay (must be activated by Terminal)

Pulse sequence of gate movements

Radio channel 1: OPEN - STOP - CLOSE - STOP - OPEN - STOP - CLOSE ...

Radio channel 2: Partial opening

Radio channel 3: OPEN - STOP - OPEN - STOP - OPEN ...

Radio channel 4: CLOSE - STOP - CLOSE - STOP - CLOSE ...

Commissioning / Operation

Deleting the radio receiver memory

1. Press and hold the Learn button (1).
 - ⇒ After 5 seconds an LED flashes - after another 10 seconds an LED is steady.
 - ⇒ After a total of 25 seconds all LEDs light.
2. Release the Learn button (1).
 - ⇒ The deletion procedure is ended.

Deleting a channel from the radio receiver

1. Press and hold the Learn button (1).
 - 1 x for channel 1; the LED (2.1) lights up.
 - 2 x for channel 2; the LED (2.2) lights up.
 - 3 x for channel 3; the LED (2.3) lights up.
 - 4 x for channel 4; the LED (2.4) lights up.
 - ⇒ The LED flashes after 5 seconds
 - ⇒ The LED lights after another 10 seconds
2. Release the learn button (1).
 - ⇒ The deletion procedure is ended.

Programming the hand-held remote control



NOTE!

The radio remote control may only be used if the gate's movement can be watched and no persons or objects are within the range of movement.



NOTE!

Before the first learning of the hand-held transmitter, delete the memory of the radio receiver.

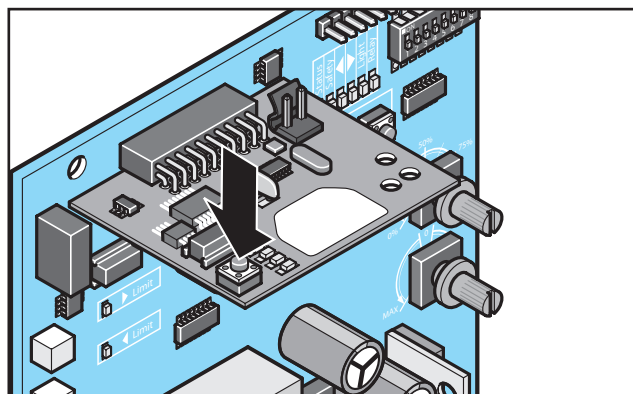

1. Press the Learn button.
 - 1 x for channel 1; the LED (2.1) lights up.
 - 2 x for channel 2; the LED (2.2) lights up.
 - 3 x for channel 3; the LED (2.3) lights up.
 - 4 x for channel 3; the LED (2.4) lights up.
 - ⇒ If no code is sent within 10 seconds, the radio receiver switches to Normal mode.
2. Press the desired hand-held transmitter button until the LED (2.1/2.2/2.3/2.4) goes out, depending which channel has been selected.
 - ⇒ LED goes out - programming is finished.
 - ⇒ The hand-held transmitter has transferred the radio code to the radio transmitter.

3. Repeat the above steps to programme additional hand-held transmitters. A maximum of 112 storage locations for each radio receiver are available.

Cancelling the Learn mode:

Press the Learn button (1) until all LEDs are out or make no input for 10 seconds.

Deleting the hand-held transmitter from the radio receiver

If a hand-held transmitter is to be deleted from the radio receiver, **every** button and **every** shortcut of the hand-held transmitter must be deleted for security reasons!

1. Press the learn button (1) and keep it pressed for five seconds.
 - ⇒ One of the LEDs flashes.
2. Release the learn button (1).
 - ⇒ The radio receiver is in Deletion mode.
3. Press the hand-held transmitter button whose code should be deleted in the radio receiver.
 - ⇒ The LED goes out. The deletion procedure is ended.
4. Repeat the procedure for **all** buttons and shortcuts.

Finishing commissioning

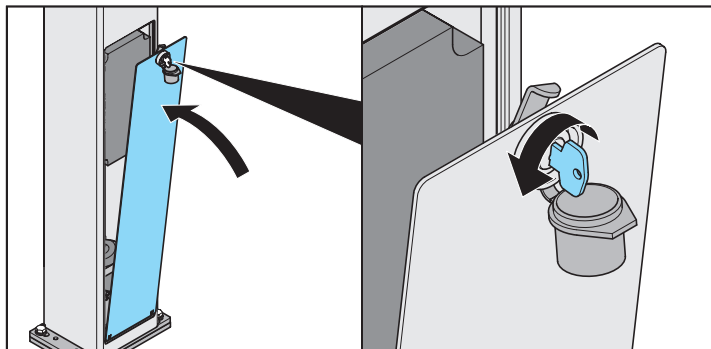

1. Insert revision flap from below and fold upwards.
2. Close revision flap.
3. Place dust cap.
 - ⇒ Commissioning complete.

Safety instructions

- The radio remote control may only be used if the gate's movement can be watched and no persons or objects are within the range of movement.
- Keep children, disabled persons and animals away from the gate.
- Never put your hand near the gate when it is moving or near moving parts.
- Only pass through the gate only once it is completely open.
- 4. Entrapment and/or cutting hazard from the mechanism or closing edges of the gate.
 - ⇒ The safety instructions in this manual and the applicable standards and directives for securing closing edges must be observed at all times.

Open gate



NOTE!

Buttons and other command controls must be installed and actuated within view of the gate only. Violation of this requirement may result in serious injury to third parties.

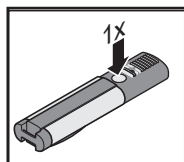

1. Press the pulse transmitter or hand-held transmitter button once.
 - Initial position gate CLOSED.
 - If the button is pressed during the gate OPEN movement, the gate stops.
 - It closes when pressed again.

Close gate

1. Press the button or hand-held transmitter button once
 - Initial position gate OPEN
 - If the button is pressed during the gate CLOSE movement, the gate stops.
 - It opens when pressed again.

Defined opening and closing

This function opens and closes the gate with separate hand-held transmitter buttons.

Defined opening:

- Programme the desired hand-held transmitter button on radio channel 3 (see p. 23).

Defined closing:

- Programme the desired hand-held transmitter button on radio channel 4 (see p. 23).

Partial opening

This function partially opens the gate.



NOTE!

A new partial opening function can only be programmed with automatic closing deactivated.



NOTE!

A partial opening of approx. 20% of the total length of the gate is factory-set. If this is to be retained, it is only necessary to programme channel 2 or to connect the button accordingly.

Example:

open the gate for persons to pass through. Partial opening can be used with a second button or by radio (hand-held transmitter, Telecody, etc.).

Partial opening by radio

1. Close gate completely to gate CLOSED end position.
2. Select radio channel 2 and programme partial opening with the desired hand-held transmitter button.
 - ⇒ See "Radio receiver".
3. Open the gate to the desired partial opening position by pressing the hand-held transmitter button programmed on channel 2 (partial opening button).
4. Press the partial opening button again when the desired partial opening position has been reached.
 - ⇒ Gate stops.
 - ⇒ The partial opening function has been programmed.

Partial opening by pulse button

1. Wire button as described in "Connection".
2. Close gate completely to the gate CLOSED end position.
3. Press button to open gate to the desired partial opening position.
4. Press button again when the desired partial opening position is reached.
 - ⇒ Gate stops.
 - ⇒ The "partial opening" function has been set.

Deleting partial opening

- Close gate to the gate CLOSED end position.
 - Press and hold PROG + hand-held transmitter button on which the partial opening was programmed for 2 seconds.
- or
- Close gate to the gate CLOSED end position.
 - Press and hold PROG + partial opening buttons for 2 seconds.
- ⇒ Light LED lights when partial opening has been deleted.

Automatic closing function



NOTE!

Risk of injury during automatic closing. Automatically closing gates may injure persons within the range of movement of the gate when closing. Always install a photo eye before activating the function. This is a legal requirement.



NOTE!

The control unit does not respond to continuous signals in the gate OPEN direction. A time clock must be connected via the photo eyes.



NOTE!

Operation with automatic closing must comply with EN 12453.



NOTE!

There are two types of automatic closing. Both allow the open holding time to be set from 0 - 255 seconds.

1. Semi-automatic closing (potentiometer left).
2. Fully automatic closing (potentiometer right).
3. Deactivating automatic closing (potentiometer at centre position).



NOTE!

The progress of the open holding time is indicated by the flashing status LED. (2 x ... 2 x...).



NOTE!

Automatic closing is disabled if dead man mode is activated (DIP 1 ON).

Semi-automatic closing function

- All commands from command transmitters are accepted.
- When the gate OPEN end position or the programmed partial opening position is reached, the open holding time starts (referred to as OHZ below).
- The gate closes on expiration of the OHZ.
- If a pulse command is received (e.g. START button or radio channel 1), the OHZ is reduced.
- The OHZ is reduced if a partial opening command is received.
- The OHZ does not expire at an intermediate stop.

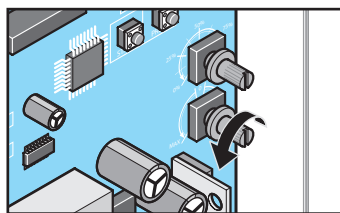

Turn potentiometer anticlockwise to the desired OHZ.

Fully automatic closing function

- All commands are ignored during opening.
- When the gate OPEN end position or the programmed partial opening position is reached, the OHZ starts.
- If a pulse command is received (e.g. START button or radio channel 1), the OHZ is restarted.
- If an new partial opening command is received at the "partial opening" drive setting, the OHZ is restarted.

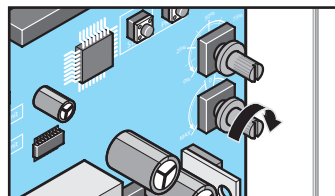

Turn potentiometer clockwise to the desired OHZ

STOP command during automatic closing

A STOP command triggered by a STOP button (see "Connection") always interrupts the movement of the drive, regardless of what type of automatic closing has been selected

Photo eye event during automatic closing

DIP switch 6:

- ON Gate closes 5 seconds after triggering photo eye.
- OFF The OHZ restarts after triggering photo eye.

Pre-warning time

Before the drive starts, a warning light flashes for 5 seconds after the button or the hand-held transmitter is pressed (factory setting).

The pre-warning time is cancelled if a command transmitter is actuated again.

- Wire warning light as described in "Connection".

DIP switch 8:

ON: Activates the pre-warning time.

OFF: Deactivates the pre-warning time.

Dead man operation

In dead man operation the gate can only be moved by continuous signals from buttons.

Dead man operation is not available by radio.



NOTE!

Force cut-off is not available in dead man operation. Risk of serious injury!

Always ensure that there are no persons, animals or object in the range of motion of the gate.



NOTE!

Buttons and other command controls must be installed and actuated within view of the gate only.

Violation of this requirement may result in serious injury to third parties.

DIP switch 1:

ON: Activates dead man operation.

- ⇒ Gate movements require the button to be pressed as long as the gate OPEN and gate CLOSE movements are required.

OFF: Deactivates dead man operation.



NOTE!

If safety devices fail, the control unit is automatically set to dead man operation. However, this only affects the movement that is affected by the fault in the safety device

Example: If a safety contact strip in the gate CLOSE direction fails, the gate can only be closed in dead man operation until the fault is repaired.

Commissioning / Operation

Obstacle detection



NOTE!

Buttons and other command controls must be installed and actuated within view of the gate only. Violation of this requirement may result in serious injury to third parties.



NOTE!

The reversing length must be set as short as possible to prevent additional hazards arising from gates with grids at an ancillary closing edge. The reversing times can be changed with the Torminal.



NOTE!

Reversing: The drive stops on contact with an obstacle and then moves in the opposite direction to release the obstacle.

Partial reversing: The drive reverses a predefined distance to release the obstacle.

Full reversing: The drive reverses completely back to the end position.

The following safety devices are installed to detect obstacles:

- Photo eye (object protection).
- Safety contact strips (personal protection).
- Force cut-off of drive (personal protection).

Obstacle detection by photo eye



NOTE!

A photo eye must be used for object protection only. A photo eye must not be used for personal protection.

- Connect photo eye as described in "Connection".

Action in gate CLOSE:

DIP 4 ON: Full reversing.

DIP 4 OFF: Partial reversing.



NOTE!

A photo eye has no effect in the gate OPEN direction.



NOTE!

If the photo eye is interrupted, the gate runs on for a short distance.

Obstacle detection by safety contact strips:

- Connect safety contact strips as described in "Connection".



NOTE!

Make absolutely sure that the safety contact strips are connected for the correct direction (OPEN/CLOSE). A safety contact strip connected for gate CLOSE will not respond in the gate OPEN direction and vice versa.

Behaviour:

DIP 2 ON: Full reversing.

DIP 2 OFF: Partial reversing.

Force cut-off of drive



NOTE!

There is no force cut-off in dead man operation. This operating mode is activated by default during the programming phase. It is also activated if DIP switch 1 is set to ON. There is a risk of serious injury for anyone in the range of movement of the gate in this operating mode.

- The sensitivity of the force cut-off depends on the correct weight setting of the gate or the weight potentiometer.
- ⇒ See "Commissioning" on p. 17.

Standby mode

To save energy, the drive control unit switches to standby mode after the specified period. Connected accessories (e.g. photo eye, safety contact strip, external radio receiver etc.) are deactivated and then reactivated at the next command (button, radio etc.).



NOTE!

The factory-set period before the control unit switches to standby mode is 6.5 minutes. The period can be changed with a Torminal. (see Torminal instructions).

Important information when using an external radio receiver:

Because external radio receivers are deactivated in standby mode, they cannot receive commands from the hand-held remote control when the control unit has switched to standby mode.

If an external radio receiver is used, standby mode must be deactivated with DIP switch 5.

Deactivating standby mode:

DIP 5 OFF: Standby activated (factory setting).

DIP 5 ON: Standby deactivated.

Important information when using a battery pack:

- If a battery pack is connected, standby mode is automatically deactivated to enable charging of the battery pack
- If there is a power failure while a battery pack is connected, the control unit automatically switches to standby mode after 5 seconds to extend the battery life. This function cannot be deactivated.

Overload protection

If the drive is overloaded during opening or closing, the control unit detects it and stops the drive.

A control unit reset returns the drive to operational status (see "Commissioning" p. 18).

Operation after a power failure

The programmed force values are retained in the event of a power failure. The first movement of the drive after a power failure is always gate OPEN.

If the power fails during a gate movement, the drive must be emergency released and the gate moved manually to an end position (see "Emergency release").

Maintenance and care

Safety instructions



DANGER!

Never use a hose or high-pressure cleaner to spray down the drive or the control unit housing.

- Before any work on the gate or drive disconnect it from the power supply and lock it to prevent reconnection.
- Do not use acids or alkalis for cleaning.
- Wipe drive clean with a dry cloth as required.
- Never put your hand near the gate when it is moving or near moving parts.
- Crush and shear hazards at the closing edges and the mechanical systems of the gate.
- Check the mounting screws and bolts of the drive for tightness and tighten if necessary.
- Check the gate according to the manufacturer's manual.

Regular testing

- Regularly check that the safety devices function correctly; no less than every six months. See EN 12453:2000.
- Test the function of pressure-sensitive safety devices (e.g. safety contact strip) every 4 weeks see EN 60335-2-95:11-2005

Testing	Behaviour	Yes or No	Possible cause	Remedy
Force cut-off Stop gate during closing with an object 50 mm x 50 mm.	Does drive reverse when it contacts the object?	Yes No	<ul style="list-style-type: none"> • Power cut-off functions • Force tolerance too high, adjust with TorMinal. • Gate incorrectly adjusted. 	<ul style="list-style-type: none"> • Reduce the force tolerance until the test is successful. First open and close the gate completely twice under supervision. See TorMinal owner's manual. • Adjust gate, call a technician.
Emergency release Proceed as described in the "Emergency Release" chapter.	The gate must be easily opened and closed by hand. (Gate is balanced).	Yes No	<ul style="list-style-type: none"> • Everything is OK. • Emergency release defective. • Gate jams. 	<ul style="list-style-type: none"> • Repair emergency release. • Check gate, see gate owner's manual.
Safety contact strip, if present. Open and close the gate and actuate the strip at the same time.	Adjust the behaviour of the gate, as set with DIP switch 1, 2 or 3. Safety LED lights continuously.	Yes No	<ul style="list-style-type: none"> • Everything is OK. • Cable breakage, terminal loose. • Strip defective. 	<ul style="list-style-type: none"> • Check the wiring; retighten the terminals. • Decommission the system and lock it to prevent reactivation. Then contact customer service.
Photo eye, if present. Open and close the gate while interrupting the photo eye.	Adjust the behaviour of the gate, as set with DIP switch 1, 2 or 3. Safety LED lights continuously.	Yes No	<ul style="list-style-type: none"> • Everything is OK. • Cable breakage, terminal loose. • Photo eye dirty. • Photo eye maladjusted (holder bent). • Photo eye defective. 	<ul style="list-style-type: none"> • Check the wiring; retighten the terminals. • Clean the photo eyes. • Adjust photo eyes. • Decommission the system and lock it to prevent reactivation. Then contact customer service.

Troubleshooting

Malfunction	Possible cause	Corrective action
Drive does not close the gate.	• Photo eyes power supply interrupted.	Check connection Replace fuse.
	• Drive has been disconnected from mains power supply.	• The drive always opens the gate completely upon first command after the power supply has been restored.
	• The drive was in an intermediate position when it was disconnected and as a result has switched to dead man operation.	• Move gate to an end position in dead man operation and lock.
Drive opens gate, then no reaction to a command from the hand-held remote control .	• Safety input triggered (e.g. photo eye defective), safety LED flashing (see table).	• Remove object from photo eye. • Repair photo eyes. • Controller not properly plugged in.
Speed varies during opening and closing.	• Drive starts and slows down before reaching the end position.	Completely normal, drive starts at maximum speed. The drive reduces speed before reaching the other end position (soft running).
Gate cannot be operated unless the user presses and holds the buttons, e.g. key switches.	• Dead man operation activated.	Deactivate dead man operation. See "Selecting DIP switch settings and repairing defective safety peripherals".
Only radio receiver!!		
All LEDs flashing.	• All memory locations occupied, max. 112.	• Delete any hand-held remote controls that are no longer needed. • Install additional radio receivers.
One of the LEDs on the receiver is on continuously.	• The radio signal is being received; the button of a hand-held remote control might be defective or an external signal is present.	• Remove the battery from the hand-held transmitter. • Wait until the external signal falls off.
One of the LEDs on the receiver is on.	• The radio receiver is in the Learning mode and awaiting a radio code from a hand-held remote control.	Press the desired hand-held transmitter button.

Description of the flash sequences of the LEDs

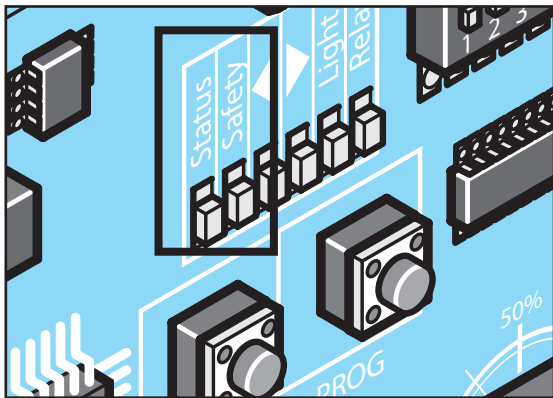

Flash sequences of the safety LED		Meaning
████████████████████	Continuously on	Emergency release is actuated, EMERGENCY STOP or stop button is pressed.
■ ■ ■ ■	2 x	Safety contact strip is bent or a force cut-off has occurred.
■ ■ ■ ■ ■ ■	3 x	Photo eye is interrupted.
■ ■ ■ ■ ■ ■ ■ ■	4 x	Runtime is >90 seconds, path is too short or too long.
■ ■ ■ ■ ■ ■ ■ ■ ■	5 x	System error: control unit has a defect or is overloaded.

Flash sequences of the status LED		Meaning
████████████████████	Continuously on	System OK.
■ ■ ■ ■	4 x	Standby mode is activated.
■ ■ ■ ■	2 x	Open time of auto closing is expiring.
■ ■	1 x	Battery charge is no longer sufficient.

DIP switch settings

Switches	ON	OFF (delivery status)
1	Dead man operation activated	Dead man operation deactivated
2	Reaction to SKL input / force cut-off	
	Full reversing	Partial reversing
3	Weight potentiometer blocked	Weight potentiometer unblocked
4	Reaction to photo eye when closing	
	Full reversing	Partial reversing
5	Standby	
	Standby deactivated	Standby activated
6	Gate closes 5 seconds after triggering photo eye	Triggering photo eye resets the open holding time
7	Gate right stop	Gate left stop
8	Pre-warning time activated	Pre-warning time deactivated

Disassembly and disposal

Emergency release



ATTENTION

During an emergency release the gate may start moving if it is not 100% horizontal.
Risk of injury!



NOTE!

It can be released in any gate position.

It should only be locked in an end position, otherwise the control unit switches to dead man operation.

Releasing drive

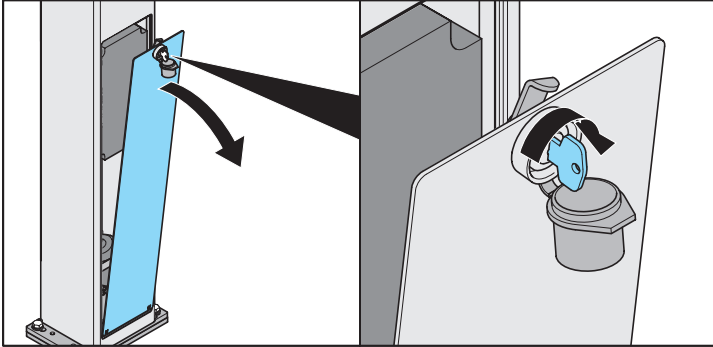

1. Open dust cap.
2. Unlock lock.
3. Open revision flap.

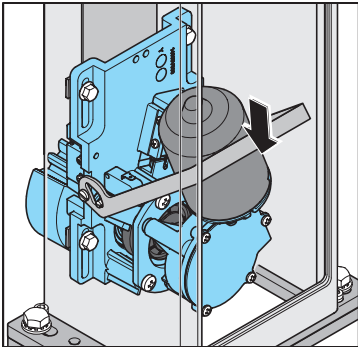

4. Push lever down.

Locking drive

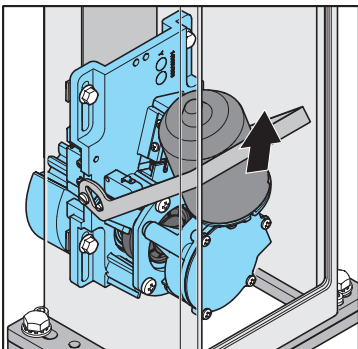

1. Push lever up.

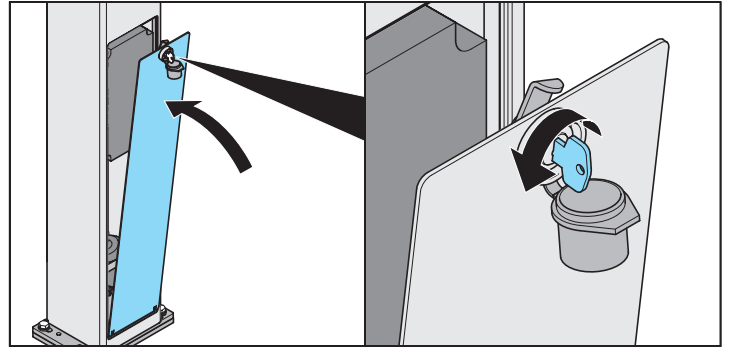

2. Position revision flap.
3. Close revision flap.
4. Place dust cap.



NOTE!

Move gate back and forth by hand so the pinion meshes with the rack more easily and the motor can lock.

⇒ Drive is locked and the gate can only be moved with the motor.

Disassembly



IMPORTANT!

Observe safety information.

The sequence is identical to that described in the "Installation" section, but in reverse order. Ignore the setting instructions.

Disposal

Observe applicable national regulations.

Warranty and customer service

The warranty complies with statutory requirements. The contact person for warranties is the specialist retailer. The warranty is only valid in the country in which the drive was purchased.

Batteries, fuses and bulbs are excluded from the warranty.

If you require after-sales service, spare parts or accessories, please contact your specialist retailer.

We have tried to make the Installation and Operating Instructions as easy as possible to follow. If you have any suggestions as to how we could improve them or if you think more information is needed, please send your suggestions to us:

Fax: 0049 / 7021 / 8001- 401

Email: doku@sommer.eu

Wiring diagram

